



*High & Low Corp.*

1994

*One Brand*

■ *More Options*

**EMC Compliance**



*High & Low Corp.*

High & Low (HAL) is a professional manufacturer developing the EMI/RFI filter solutions.

The head office is based in Taipei Taiwan and factory in Shenzhen China. Combing award-winning technology, expertise and advantageous conditions of location, HAL provides customers with highly relevant results, competitive price, rapid delivery, good quality and full support for marketing demands.

## **EMI / RFI Filter**

**Drilling  
industry**



**Audio  
processor**



**Military  
machinery**



**Diagnostic  
imaging  
device**



**Portable  
power  
generator**



**Collaborative  
robotics**

**Testing &  
Measuring**



**Surgical  
chair**



**Automotive electronics**



**Household electric appliance**



**Medical devices**



**Telecom equipment**

**Heavy electric machinery**



*High & Low*

**Computer & Peripherals**



**Printing technology**



**Renewable sources**

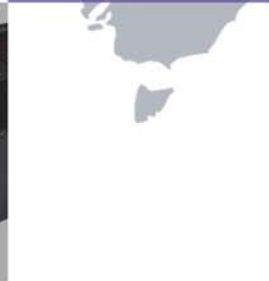

### IEC Inlet Filter

- General Purpose ..... 01~02
- High Performance ..... 03~04
- Excellent Performance ..... 05~06
- PCB mountable ..... 07~08
- Right Angle ..... 09~10



### Power Entry Module

- Socket + Fuse Holder ..... 11~12
- Socket + Fuse Holder | Waterproof ..... 13~14
- Socket + Switch ..... 15~16
- Socket + Fuse Holder + Switch ..... 17~18
- Installation Instructions For Fuse ..... 55



### Single Phase Filter

#### Metal Chassis

- General Purpose ..... 19~20
- High Performance ..... 21~22
- Excellent Performance ..... 23~24



#### Plastic Chassis

- General Purpose ..... 25~26
- High Performance ..... 27~30



### Home Appliance Filter

- General Purpose ..... 31~32



### PCB Filter

- General Purpose ..... 33~34



### 3 Phase Filter

- 3 Wired ..... 35~48
- 4 Wired ..... 49~54





Single Phase

General Purpose				
IEC Inlet Filter	Power Entry Module	Single Phase Filter	Home Appliance Filter	PCB Filter
<b>General purpose</b> P01 ≤20A SS1- SS1-.B	<b>Socket + fuse holder</b> P11 ≤10A SS3-..S SS3-..U SS3-A.S	<u>Metal Chassis</u> <b>General purpose</b> P19 ≤30A SS4-1A...-B SS4-1B	<b>General purpose</b> P31 ≤16A S7D	<b>General purpose</b> P33 ≤20A 41AA / 42DC
<b>High performance</b> P03 ≤20A SS1K-.CE	<b>Socket + switch</b> P15 ≤10A SS3-..S SS3-..U SS3-A.S	<b>High performance</b> P21 ≤20A SS4-2D/2F/2G		
<b>Excellent performance</b> P05 ≤20A SS1M-.DA SS1M-.DB		<b>Excellent performance</b> P23 ≤20A S4-3A/3B/4A		
<b>PCB mountable</b> P07 ≤15A SS2-.S SS2-.B	<b>Socket + fuse holder + switch</b> P17 ≤10A SS6-.AH SS6-.AI SS6-.BH	<u>Plastic Chassis</u> <b>General purpose</b> P25 ≤30A CNAC/CNAH		
<b>Right angle</b> P09 ≤15A SS2-LS SS2-LB		<b>High performance</b> P27 ≤20A CEAC/CEAP CNBC		

Phase

Medical Compliance			
IEC Inlet Filter	Power Entry Module	Single Phase Filter	PCB Filter
<b>General purpose</b> P01 ≤15A SS1A-	<b>Socket + fuse holder</b> P11 ≤10A SS3A-..S	<u>Metal Chassis</u> <b>General purpose</b> P19 ≤30A SS4A-1A...-B	<b>General purpose</b> P33 ≤10A 4A1AA
<b>High performance</b> P03 ≤15A SS1L-.CE	<b>Socket + switch</b> P15 ≤10A SS3A-..S	<b>High performance</b> P21 ≤15A SS4A-2D	
<b>Excellent performance</b> P05 ≤20A SS1N-.DA	<b>Socket + fuse holder + switch</b> P17 ≤10A SS6A-.AH	<u>Plastic Chassis</u> <b>General purpose</b> P25 ≤30A CNAM	
<b>PCB mountable</b> P07 ≤15A SS2A-.S		<b>High performance</b> P27 ≤20A CEAM CNBM	
<b>Right angle</b> P09 ≤15A SS2A-LS			

3 Phase

3 Wired
SCB58 ≤400A P35
SCJ25 / SCJ26 ≤30A P37
SCA00 ≤400A P39
SCA20H ≤400A P41
SB58 ≤400A P43
SC51H ≤400A P45
CTAC / CTAH ≤30A P47

4 Wired
SCB56H ≤400A P49
SC56 ≤400A P51
SC55 ≤20A P53

# IEC INLET FILTER

## General Purpose

### Features

- General conducted attenuation performance
- Compact design, lower cost
- With IEC320 AC socket
- Current rating 1A~20A
- Practical solution for general and medical devices

### Marketing Applications

- IPC
- Claw machine
- UPS
- SMPS
- Power supply

### Numbering System

1 SS1 2 - 3 4 5 6 - 7 ( 8 )

1 Rated current

01,03,06,10,15,20

2 Electrical schematic

**Blank:** standard  
**A:** medical compliance

3 Type of case (refer P02 Mechanical drawing)

**Blank:** screw mounting, only for 1~15A, please add **8**  
**P:** snap-in mounting, only for 1~15A  
**F:** screw mounting, only for 20A

4 Components value (refer P02 Filter selection table)

**Blank:** Cx=0.1uF, Cy=2.2nF  
**B:** Cx=0.1uF, Cy=3.3nF

5 Grounded choke (optional)

**G:** Lg= 100uH

6 Bleeder resistor (optional)

**R:** R= 1M ohm; 1/4W min.

7 Output connections (refer P02 Output terminal)

**Q:** fast-on tab (6.3mm)  
**W:** with wired (100mm)

8 Type of case

**S:** screw mounting, only for 1~15A

### Electrical Schematic

● **Blank:** standard

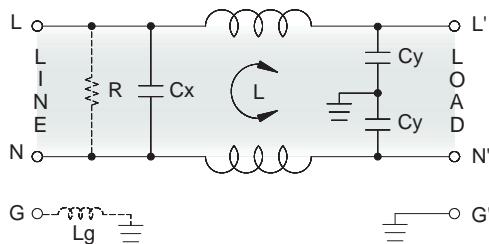

● **A:** medical compliance

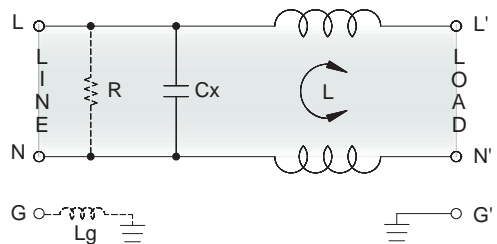

### Filter Attenuation

Insertion loss (dB) in 50 ohm system CISPR 17 (for reference only)

■ 1A~3A

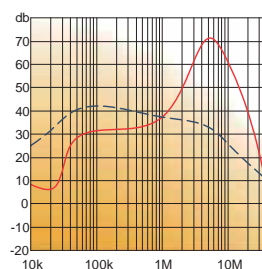

■ 6A~10A

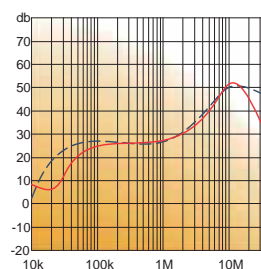

■ 15A

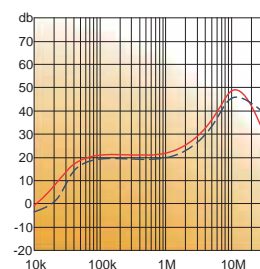

■ 20A

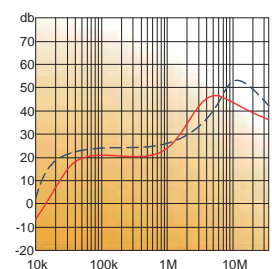

Common mode / Asymmetric (L-G) ————  
Differential mode / Symmetric (L-L) - - - - -

## Filter Selection Table •

Filter Part No.	Rated Current @50°C [A]	Leakage Current @250VAC/50Hz [μA]	Inductance @10KHz,0.25V [mH]	Capacitance		Output terminal	
				Cx [μF]	Cy [nF]		
<b>Blank: standard</b>							
01SS1-...	1	450	6.5	0.1	2.2	-Q	-W
03SS1-...	3	450	2.5	0.1	2.2	-Q	-W
06SS1-...	6	450	0.8	0.1	2.2	-Q	-W
10SS1-...	10	450	0.2	0.1	2.2	-Q	-W
15SS1-...	15	450	0.2	0.1	2.2	-Q	-W
20SS1-...	20	450	0.5	0.1	2.2	-Q	-W
01SS1-.B..	1	600	3.7	0.1	3.3	-Q	-W
03SS1-.B..	3	600	1.8	0.1	3.3	-Q	-W
06SS1-.B..	6	600	0.8	0.1	3.3	-Q	-W
10SS1-.B..	10	600	0.3	0.1	3.3	-Q	-W
15SS1-.B..	15	600	0.2	0.1	3.3	-Q	-W
20SS1-.B..	20	600	0.5	0.1	3.3	-Q	-W
<b>A: medical compliance</b>							
01SS1A-...	1	5	6.5	0.1	-	-Q	-W
03SS1A-...	3	5	2.5	0.1	-	-Q	-W
06SS1A-...	6	5	0.8	0.1	-	-Q	-W
10SS1A-...	10	5	0.2	0.1	-	-Q	-W
15SS1A-...	15	5	0.2	0.1	-	-Q	-W

## Output Terminal

(unit: mm)

- **Q:** fast-on tab based on UL310 standard

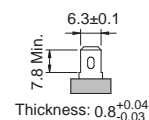
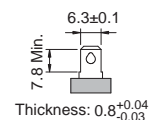

- **W:** with wired stripped and tinned

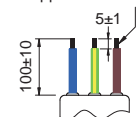

## Mechanical Drawing (unit: mm) •

- **Blank(S)**

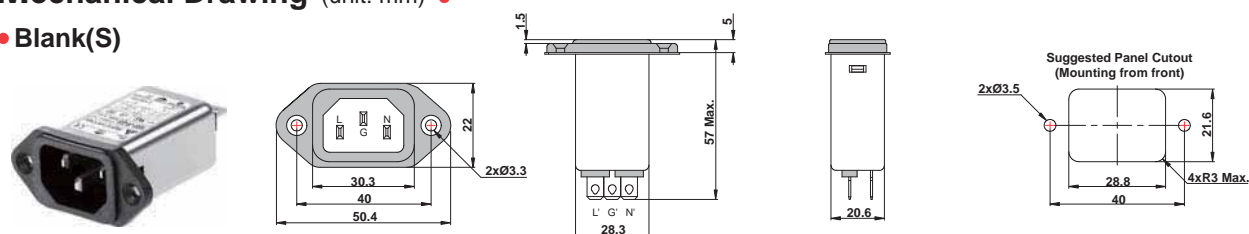

- **P**

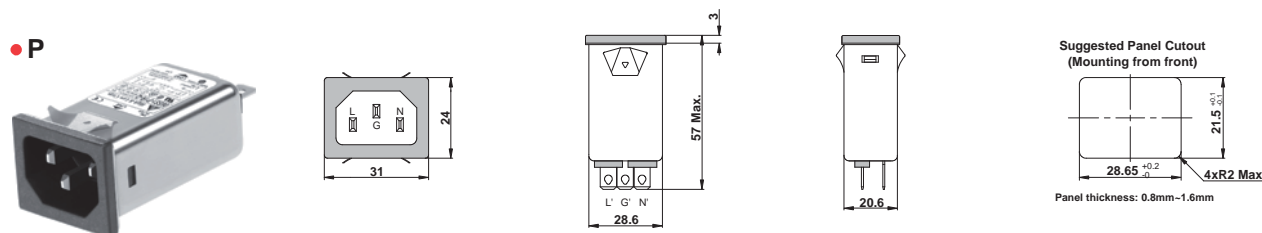

- **F**

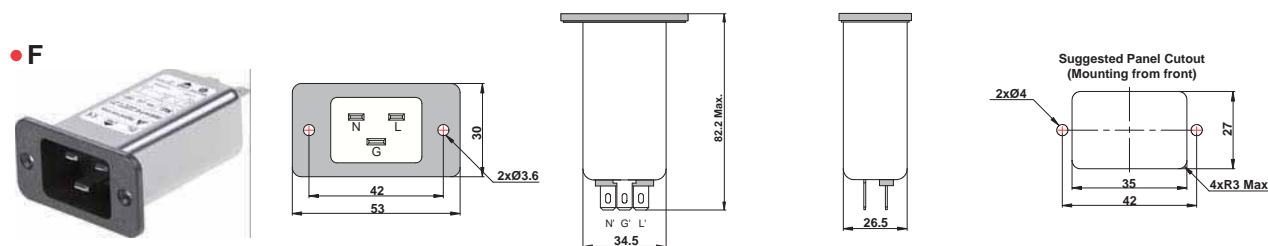



# IEC INLET FILTER

## High Performance

### Features

- Superior conducted attenuation performance
- Compact design, lower cost
- With IEC320 AC socket
- Current rating 1A~20A
- Practical solution for general and medical devices

### Marketing Applications

- DC applications
- Measuring instruments
- Portable electrical and electronic equipment
- Medical device (not body-coupled)
- Audio and video processor

### Numbering System

1 SS1 2 - 3 4 5 6 - 7 ( 8 )

1 Rated current

01,03,06,10,15,20

2 Electrical schematic

K: high performance  
L: medical compliance

3 Type of case (refer P04 Mechanical drawing)

Blank: screw mounting, only for 1~15A, please add 8  
P: snap-in mounting, only for 1~15A  
F: screw mounting, only for 20A

4 Components value (refer P04 Filter selection table)

CE: Cx=0.22uF, Cy=2.2nF  
CF: Cx=0.22uF, Cy=3.3nF

5 Grounded choke (optional)

G: Lg= 100uH

6 Bleeder resistor (optional)

R: R= 1M ohm; 1/4W min.

7 Output connections (refer P04 Output terminal)

Q: fast-on tab (6.3mm)  
W: with wired (100mm)

8 Type of case

S: screw mounting, only for 1~15A

### Electrical Schematic

● K: high performance

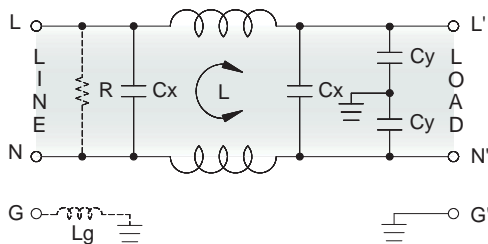

● L: medical compliance

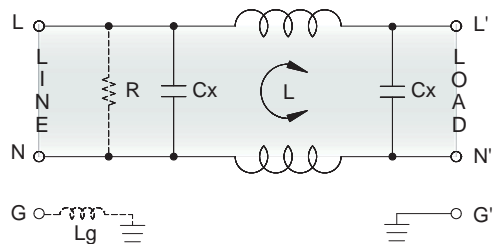

### Filter Attenuation

Insertion loss (dB) in 50 ohm system CISPR 17 (for reference only)

■ 1A~3A

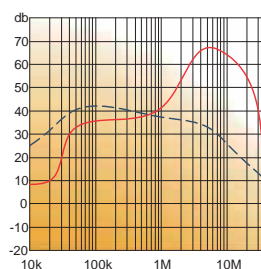

■ 6A~10A

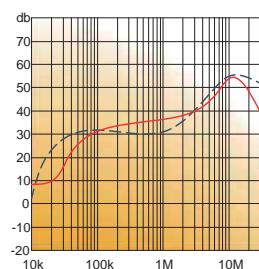

■ 15A

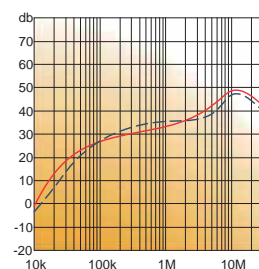

■ 20A

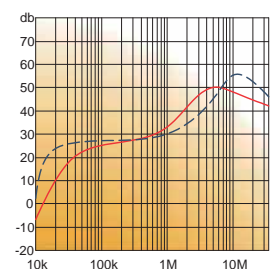

Common mode / Asymmetric (L-G) ————  
Differential mode / Symmetric (L-L) - - - - -

## Filter Selection Table •

Filter Part No.	Rated Current @50°C [A]	Leakage Current @250VAC/50Hz [μA]	Inductance @10KHz,0.25V [mH]	Capacitance		Output terminal	
				Cx [μF]	Cy [nF]		
<b>K: high performance</b>							
01SS1K-.CE..	1	450	10	0.22	2.2	-Q	-W
03SS1K-.CE..	3	450	3	0.22	2.2	-Q	-W
06SS1K-.CE..	6	450	1.2	0.22	2.2	-Q	-W
10SS1K-.CE..	10	450	1.2	0.22	2.2	-Q	-W
15SS1K-.CE..	15	450	0.7	0.22	2.2	-Q	-W
01SS1K-.CF..	1	600	10	0.22	3.3	-Q	-W
03SS1K-.CF..	3	600	3	0.22	3.3	-Q	-W
06SS1K-.CF..	6	600	1.2	0.22	3.3	-Q	-W
10SS1K-.CF..	10	600	1.2	0.22	3.3	-Q	-W
15SS1K-.CF..	15	600	0.7	0.22	3.3	-Q	-W
20SS1K-.CF..	20	600	0.5	0.22	3.3	-Q	-W
<b>L: medical compliance</b>							
01SS1L-.CE..	1	5	10	0.22	-	-Q	-W
03SS1L-.CE..	3	5	3	0.22	-	-Q	-W
06SS1L-.CE..	6	5	1.2	0.22	-	-Q	-W
10SS1L-.CE..	10	5	1.2	0.22	-	-Q	-W
15SS1L-.CE..	15	5	0.7	0.22	-	-Q	-W

## Output Terminal

(unit: mm)

- **Q:** fast-on tab based on UL310 standard

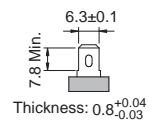
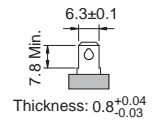

- **W:** with wired stripped and tinned

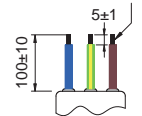

## Mechanical Drawing (unit: mm) •

- **Blank(S)**

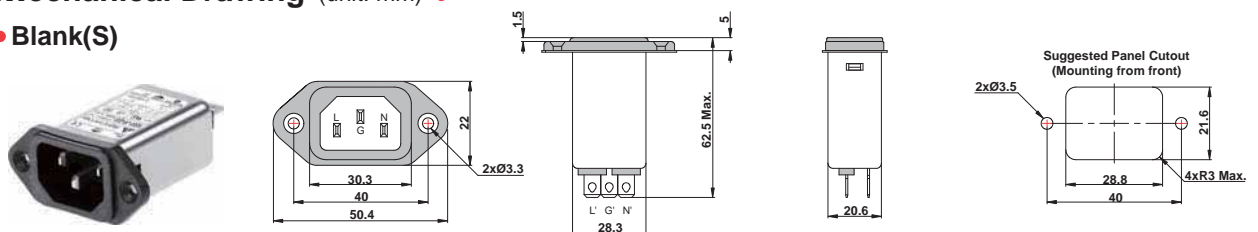

- **P**

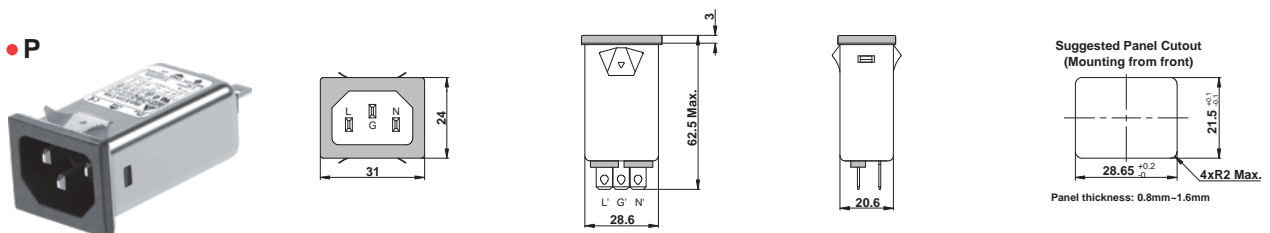

- **F**

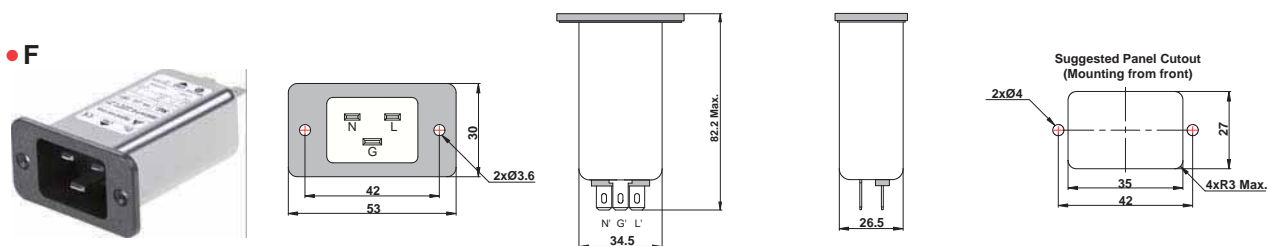

# IEC INLET FILTER

**Excellent Performance**

## Features

- Ultra-high conducted attenuation performance
- Compact design, lower cost
- With IEC320 AC socket
- Current rating 1A~20A
- Practical solution for general and medical devices

## Marketing Applications

- Conferencing system
- Light sensor system
- Auxiliary power supply
- Endoscopy light source
- Label printer

## Numbering System

**1 SS1 2 - 3 4 5 6 - 7 ( 8 )**

**1** Rated current

01,03,06,10,15,20

**2** Electrical schematic

**M:** excellent performance  
**N:** medical compliance

**3** Type of case (refer P06 Mechanical drawing)

**Blank:** screw mounting, only for 1~15A, please add **8**  
**F:** screw mounting, only for 20A

**4** Components value (refer P06 Filter selection table)

**DA:** Cx=0.1uF, Cy=2.2nF  
**DB:** Cx=0.1uF, Cy=3.3nF

**5** Grounded choke (optional)

**G:** Lg= 100uH

**6** Bleeder resistor (optional)

**R:** R= 1M ohm; 1/4W min.

**7** Output connections (refer P06 Output terminal)

**Q:** fast-on tab (6.3mm)  
**W:** with wired (100mm)

**8** Type of case

**T:** screw mounting, only for 1~15A

## Electrical Schematic

● **M:** excellent performance

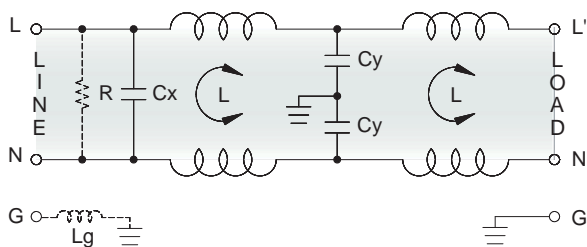

● **N:** medical compliance

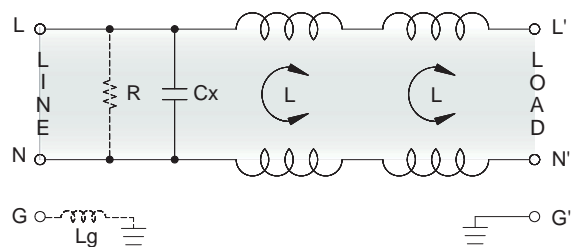

## Filter Attenuation

Insertion loss (dB) in 50 ohm system CISPR 17 (for reference only)

■ 1A~3A

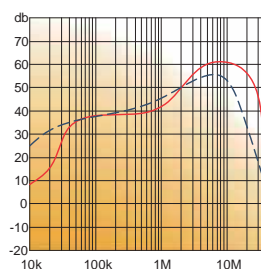

■ 6A~10A

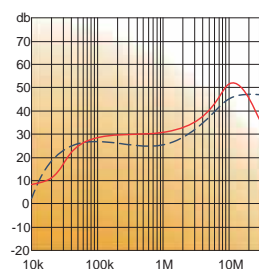

■ 15A

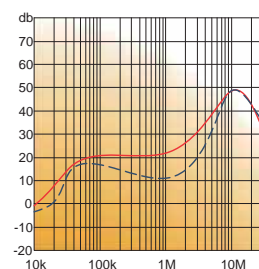

■ 20A

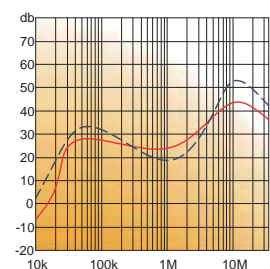

Common mode / Asymmetric (L-G) ————  
Differential mode / Symmetric (L-L) - - - - -

## Filter Selection Table •

Filter Part No.	Rated Current @50°C [A]	Leakage Current @250VAC/50Hz [μA]	Inductance @10KHz,0.25V [mH]	Capacitance Cx [μF]    Cy [nF]		Output terminal	
<b>M: excellent performance</b>							
01SS1M-.DA..	1	450	3+1.1	0.1	2.2	-Q	-W
03SS1M-.DA..	3	450	3+1.1	0.1	2.2	-Q	-W
06SS1M-.DA..	6	450	1.5+0.8	0.1	2.2	-Q	-W
10SS1M-.DA..	10	450	1+0.3	0.1	2.2	-Q	-W
15SS1M-.DA..	15	450	0.5+0.2	0.1	2.2	-Q	-W
20SS1M-.DA..	20	450	0.3+0.1	0.1	2.2	-Q	-W
01SS1M-.DB..	1	600	3+1.1	0.1	3.3	-Q	-W
03SS1M-.DB..	3	600	3+1.1	0.1	3.3	-Q	-W
06SS1M-.DB..	6	600	1.5+0.8	0.1	3.3	-Q	-W
10SS1M-.DB..	10	600	1+0.3	0.1	3.3	-Q	-W
15SS1M-.DB..	15	600	0.5+0.2	0.1	3.3	-Q	-W
20SS1M-.DB..	20	600	0.3+0.1	0.1	3.3	-Q	-W
<b>N: medical appliance</b>							
01SS1N-.DA..	1	5	3+1.1	0.1	-	-Q	-W
03SS1N-.DA..	3	5	3+1.1	0.1	-	-Q	-W
06SS1N-.DA..	6	5	1.5+0.8	0.1	-	-Q	-W
10SS1N-.DA..	10	5	1+0.3	0.1	-	-Q	-W
15SS1N-.DA..	15	5	0.5+0.2	0.1	-	-Q	-W
20SS1N-.DA..	20	5	0.3+0.1	0.1	-	-Q	-W

## Output Terminal

(unit: mm)

- **Q:** fast-on tab based on UL310 standard

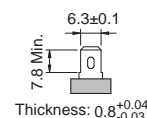
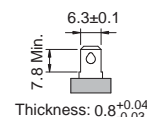

- **W:** with wired stripped and tinned

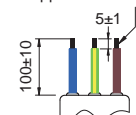

## Mechanical Drawing (unit: mm) •

- **Blank(T)**

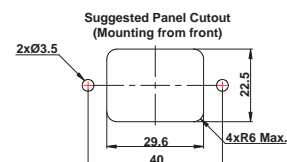
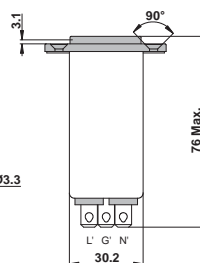
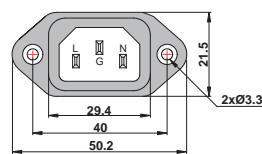

- **F**

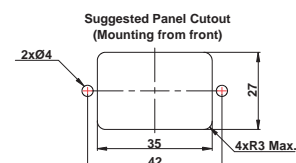
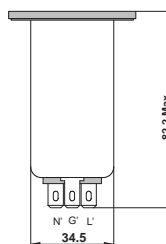
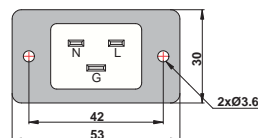

# IEC INLET FILTER

**PCB Mountable**

## Features

- General conducted attenuation performance
- Easy to install, compact size
- Current rating 1A~15A
- With good HF coupling to the equipment housing
- With PCB through hole pins output terminals

## Marketing Applications

- Surveillance system
- Test and measurement equipment
- Rack mounting equipment
- EDP and office equipment
- Medical device (not body-coupled)

## Numbering System

**1** SS2 **2** - **3** **4** **5** **6**

**1** Rated current  
01,03,06,10,15

**2** Electrical schematic  
**Blank:** standard  
**A:** medical compliance

**3** Type of case (refer P08 Mechanical drawing)  
**P,P1,PG**

**4** Components value (refer P08 Filter selection table)  
**S:** Cx=0.1uF, Cy=2.2nF  
**B:** Cx=0.1uF, Cy=3.3nF

**5** Grounded choke (optional)  
**G:** Lg= 100uH

**6** Bleeder resistor (optional)  
**R:** R= 1M ohm; 1/4W min.

## Electrical Schematic

● **Blank:** standard

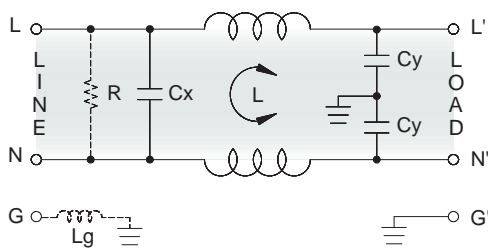

● **A:** medical compliance

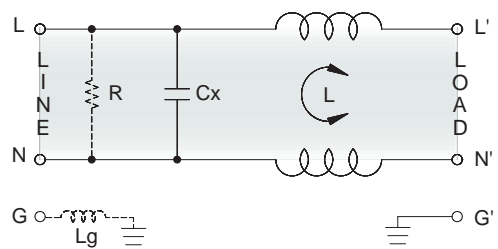

## Filter Attenuation

Insertion loss (dB) in 50 ohm system CISPR 17 (for reference only)

■ 1A~3A

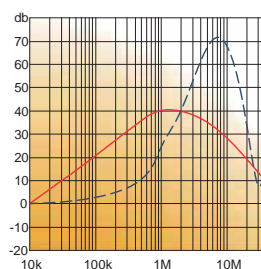

■ 6A~10A

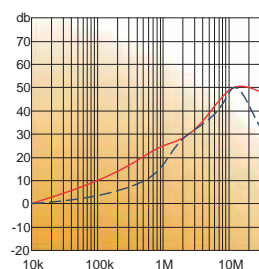

■ 15A

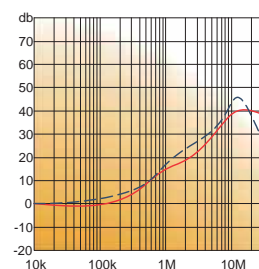

Common mode / Asymmetric (L-G) ————  
Differential mode / Symmetric (L-L) - - - - -

## Filter Selection Table ●

Filter Part No.	Rated Current @50°C [A]	Leakage Current @250VAC/50Hz [μA]	Inductance @10KHz,0.25V [mH]	Capacitance Cx [μF]	Cy [nF]
<b>Blank: standard</b>					
01SS2-.S..	1	450	6.5	0.1	2.2
03SS2-.S..	3	450	2.5	0.1	2.2
06SS2-.S..	6	450	0.8	0.1	2.2
10SS2-.S..	10	450	0.2	0.1	2.2
15SS2-.S..	15	450	0.2	0.1	2.2
01SS2-.B..	1	600	3.7	0.1	3.3
03SS2-.B..	3	600	1.8	0.1	3.3
06SS2-.B..	6	600	0.8	0.1	3.3
10SS2-.B..	10	600	0.3	0.1	3.3
15SS2-.B..	15	600	0.2	0.1	3.3
<b>A: medical compliance</b>					
01SS2A-.S..	1	5	6.5	0.1	-
03SS2A-.S..	3	5	2.5	0.1	-
06SS2A-.S..	6	5	0.8	0.1	-
10SS2A-.S..	10	5	0.2	0.1	-
15SS2A-.S..	15	5	0.2	0.1	-

## Mechanical Drawing (unit: mm) ●

● P

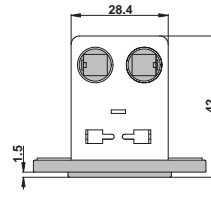
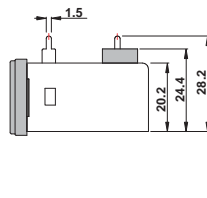
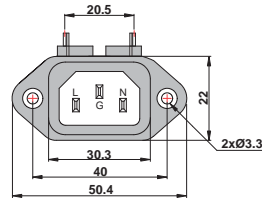

Suggested PCB Layout

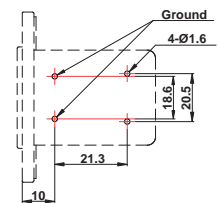

● P1

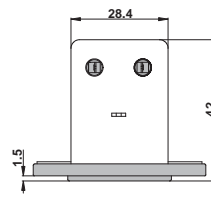
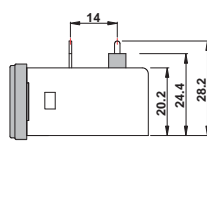
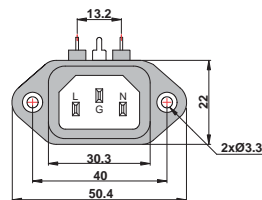

Suggested PCB Layout

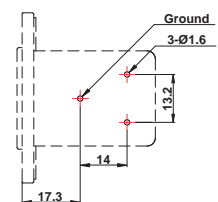

● PG: with grounded choke

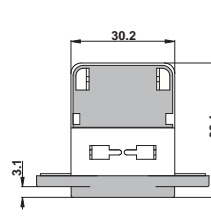
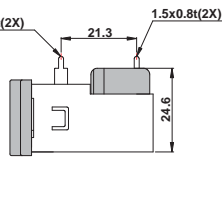
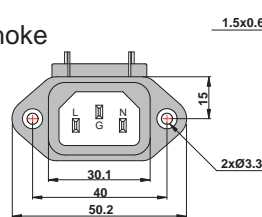

Suggested PCB Layout

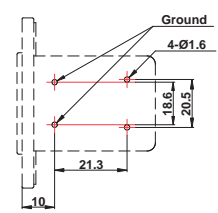

# IEC INLET FILTER

## Right angle

### Features

- Right angle for output terminal
- Compact multi-purpose filter
- Current rating 1A~15A
- Various output connections
- Practical solution for general and medical devices

### Marketing Applications

- Measuring instruments
- Household application
- Energy management system
- Food processing equipment
- Medical device (not body-coupled)

### Numbering System

**1** SS2 **2** - L **3** **4** **5** - **6**

**1** Rated current

01,03,06,10,15

**2** Electrical schematic

**Blank:** standard  
**A:** medical compliance

**3** Components value (refer P10 Filter selection table)

**S:** Cx=0.1uF, Cy=2.2nF  
**B:** Cx=0.1uF, Cy=3.3nF

**4** Grounded choke (optional)

**G:** Lg= 100uH

**5** Bleeder resistor (optional)

**R:** R= 1M ohm; 1/4W min.

**6** Output connections (refer P10 Output terminal)

**Q:** fast-on tab (6.3mm)  
**S:** solder tab tab (4mm)  
**W:** with wired (100mm)

### Electrical Schematic

● **Blank:** standard

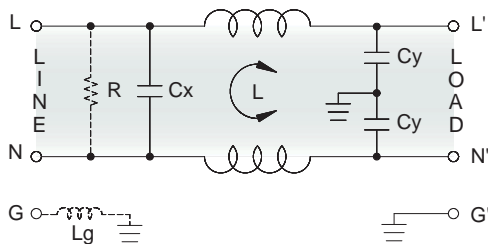

● **A:** medical compliance

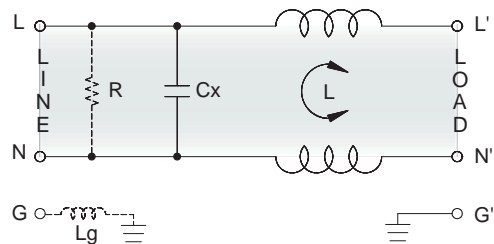

### Filter Attenuation

Insertion loss (dB) in 50 ohm system CISPR 17 (for reference only)

■ 1A~3A

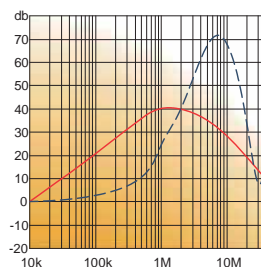

■ 6A~10A

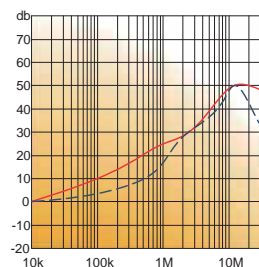

■ 15A

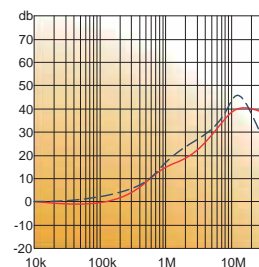

Common mode / Asymmetric (L-G) ————  
Differential mode / Symmetric (L-L) - - - - -

## Filter Selection Table •

Filter Part No.	Rated Current @50°C [A]	Leakage Current @250VAC/50Hz [μA]	Inductance @10KHz,0.25V [mH]	Capacitance		Output terminal		
				Cx [μF]	Cy [nF]			
<b>Blank: standard</b>								
01SS2-LS..	1	450	6.5	0.1	2.2	-Q	-S	-W
03SS2-LS..	3	450	2.5	0.1	2.2	-Q	-S	-W
06SS2-LS..	6	450	0.8	0.1	2.2	-Q	-S	-W
10SS2-LS..	10	450	0.2	0.1	2.2	-Q	-S	-W
15SS2-LS..	15	450	0.2	0.1	2.2	-Q	-S	-W
01SS2-LB..	1	600	3.7	0.1	3.3	-Q	-S	-W
03SS2-LB..	3	600	1.8	0.1	3.3	-Q	-S	-W
06SS2-LB..	6	600	0.8	0.1	3.3	-Q	-S	-W
10SS2-LB..	10	600	0.3	0.1	3.3	-Q	-S	-W
15SS2-LB..	15	600	0.2	0.1	3.3	-Q	-S	-W
<b>A: medical compliance</b>								
01SS2A-LS..	1	5	6.5	0.1	-	-Q	-S	-W
03SS2A-LS..	3	5	2.5	0.1	-	-Q	-S	-W
06SS2A-LS..	6	5	0.8	0.1	-	-Q	-S	-W
10SS2A-LS..	10	5	0.2	0.1	-	-Q	-S	-W
15SS2A-LS..	15	5	0.2	0.1	-	-Q	-S	-W

## Output Terminal

(unit: mm)

- **Q:** fast-on tab based on UL310 standard

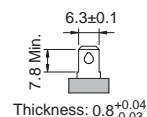

- **S:** solder tab based on UL 310 standard

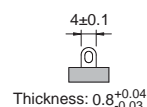

- **W:** with wired stripped and tinned

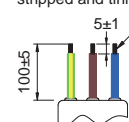

## Mechanical Drawing (unit: mm) •

- **L-Q**

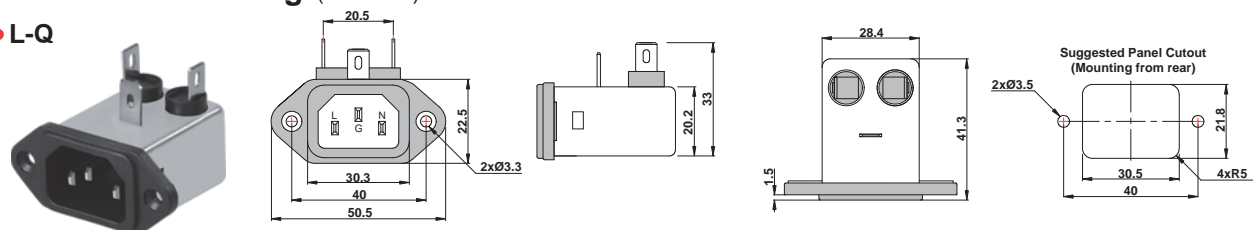

- **L-S**

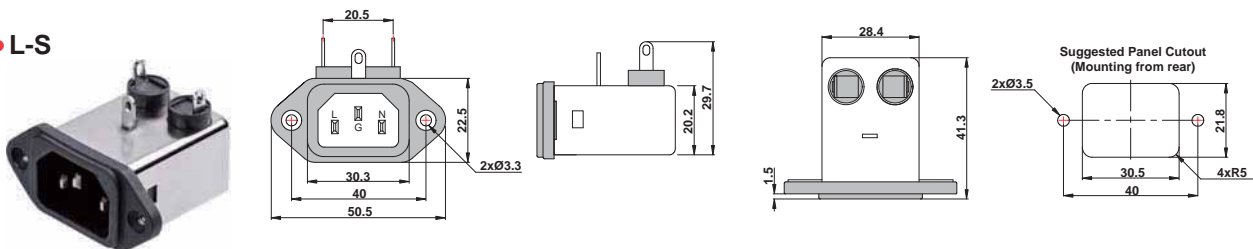

- **L-W**

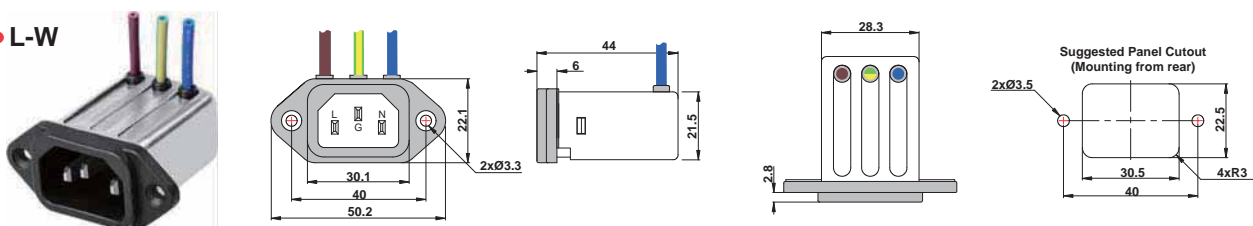



# POWER ENTRY MODULE

## Socket + Fuse holder

### Features

- General conducted attenuation performance
- Easy to install, compact size
- Front mounting
- Current rating 1A~10A
- With IEC320 AC socket and fuse holder

### Marketing Applications

- Controls and communication systems
- Rack mounting equipment
- Audio and video processor
- Slot machine
- Lighting equipment

### Numbering System

1 SS3 2 - 3 4 5 6 7 8 - 9 (10)

1 Rated current

01,02,04,06,10

2 Electrical schematic

Blank: standard

A: medical compliance, without Cy cap.

3 Additional schematic (optional)

A: high performance

4 Fuse holder

1: can be installed single fuse

2: can be installed dual fuses

5 Type of case (refer P12 Mechanical drawing)

Blank: screw mounting

P: snap-in mounting with up & down spring

6 Components value (refer P12 Filter selection table)

S: Cx=0.1uF, Cy=2.2nF

U: Cx=0.1uF, Cy=0.47nF

7 Grounded choke (optional)

G: Lg= 100uH

8 Bleeder resistor (optional)

R: R= 1M ohm; 1/4W min.

9 Output connections (refer P12 Output terminal)

Q: fast-on tab (6.3mm)

W: with wired (100mm)

10 Type of case (optional)

S: short version

### Electrical Schematic

Blank: standard

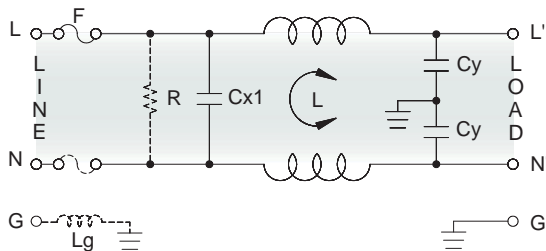

A: high performance

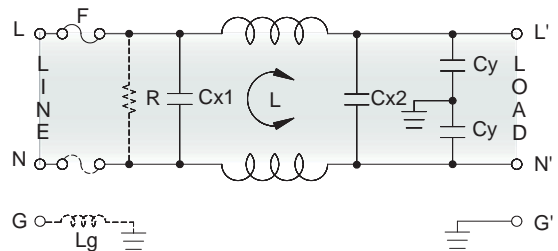

### Filter Attenuation

Insertion loss (dB) in 50 ohm system CISPR 17 (for reference only)

1A~3A

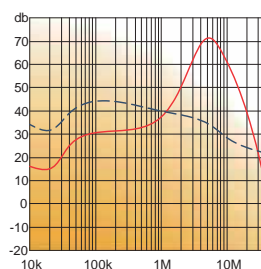

4A~6A

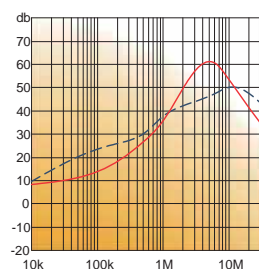

8A~10A

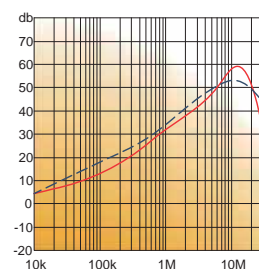

Common mode / Asymmetric (L-G) ————  
Differential mode / Symmetric (L-L) - - - - -

## Filter Selection Table •

Filter Part No.	Rated Current @50°C [A]	Leakage Current @250VAC/50Hz [µA]	Inductance @10KHz,0.25V [mH]	Capacitance			Output terminal	
				Cx1 [µF]	Cx2 [µF]	Cy [nF]		
<b>Blank: standard</b>								
01SS3-..S..	1	450	6.5	0.1	-	2.2	-Q	-W
02SS3-..S..	2	450	3.8	0.1	-	2.2	-Q	-W
04SS3-..S..	4	450	1.6	0.1	-	2.2	-Q	-W
06SS3-..S..	6	450	0.8	0.1	-	2.2	-Q	-W
10SS3-..S..	10	450	0.2	0.1	-	2.2	-Q	-W
01SS3-..U..	1	100	11	0.1	-	0.47	-Q	-W
02SS3-..U..	2	100	6.5	0.1	-	0.47	-Q	-W
04SS3-..U..	4	100	4.2	0.1	-	0.47	-Q	-W
06SS3-..U..	6	100	1.6	0.1	-	0.47	-Q	-W
10SS3-..U..	10	100	0.4	0.1	-	0.47	-Q	-W
<b>A: high performance</b>								
01SS3-A.S..	1	450	6.5	0.1	0.1	2.2	-Q	-W
02SS3-A.S..	2	450	3.8	0.1	0.1	2.2	-Q	-W
04SS3-A.S..	4	450	1.6	0.1	0.1	2.2	-Q	-W
06SS3-A.S..	6	450	0.8	0.1	0.1	2.2	-Q	-W
10SS3-A.S..	10	450	0.2	0.1	0.1	2.2	-Q	-W
<b>A: medical compliance</b>								
01SS3A-..S..	1	5	6.5	0.1	-	-	-Q	-W
02SS3A-..S..	2	5	3.8	0.1	-	-	-Q	-W
04SS3A-..S..	4	5	1.6	0.1	-	-	-Q	-W
06SS3A-..S..	6	5	0.8	0.1	-	-	-Q	-W
10SS3A-..S..	10	5	0.2	0.1	-	-	-Q	-W

## Output Terminal

(unit: mm)

- **Q:** fast-on tab based on UL310 standard

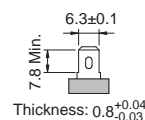
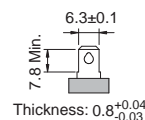

- **W:** with wired stripped and tinned

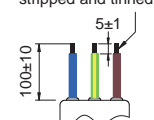

## Mechanical Drawing (unit: mm) ••

- **Blank:** screw mounting

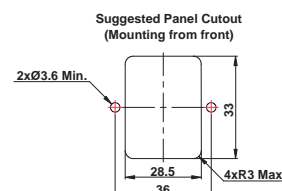
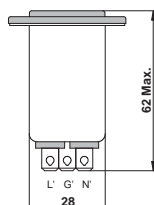
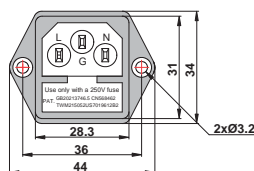

- **Blank(S):** screw mounting. short version

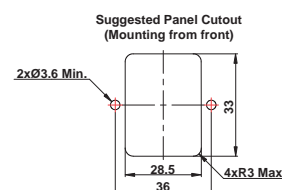
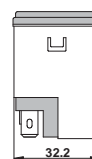
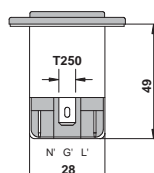
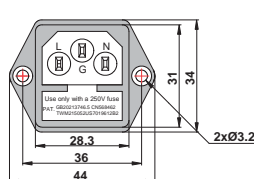

- **P:** snap-in mounting with up & down spring

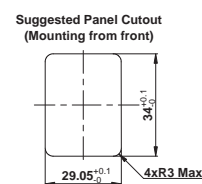
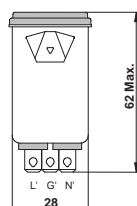
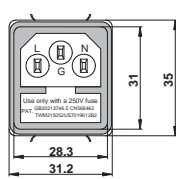

- **P(S):** snap-in mounting with up & down spring. short version

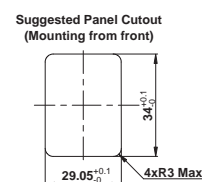
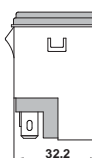
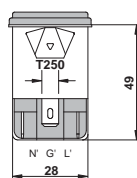
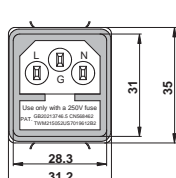

# POWER ENTRY MODULE

## Socket + Fuse holder | Waterproof

### Features

- Compact design with waterproof kit included
- Superior conducted attenuation performance
- Screw mounting
- Current rating 1A~10A
- IP65 acc. to IEC 60529 against liquids or mist

### Marketing Applications

- Infusion pump (medical)
- Medical device (not body-coupled)
- Surveillance system
- EDP system
- Measuring instruments

### Numbering System

**1** SS3 **2** - **3** **4** **5** **6** **7** - **8**

#### 1 Rated current

01,02,04,06,10

#### 2 Electrical schematic

**Blank:** standard

**A:** medical compliance, without Cy cap.

#### 3 Additional schematic (optional)

**A:** high performance

#### 4 Fuse holder

1: can be installed single fuse

2: can be installed dual fuses

#### 5 Components value (refer P14 Filter selection table)

**S:** Cx=0.1uF, Cy=2.2nF

**U:** Cx=0.1uF, Cy=0.47nF

#### 6 Grounded choke (optional)

**G:** Lg= 100uH

#### 7 Bleeder resistor (optional)

**R:** R= 1M ohm; 1/4W min.

#### 8 Output connections (refer P14 Output terminal)

**Q:** fast-on tab (6.3mm)

### Electrical Schematic •

#### • Blank: standard

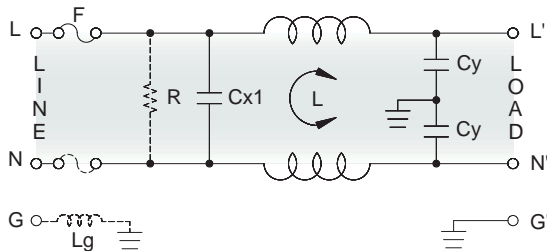

#### • A: high performance

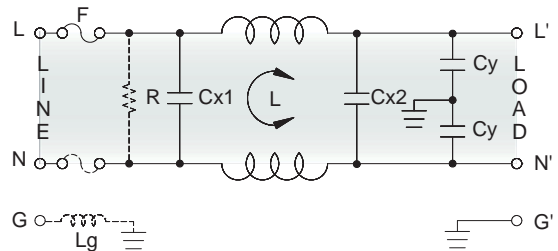

### Filter Attenuation Insertion loss (dB) in 50 ohm system CISPR 17 (for reference only)

#### ■ 1A~3A

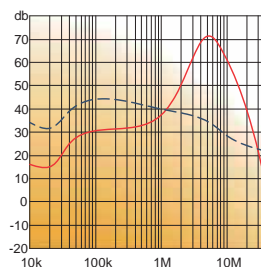

#### ■ 4A~6A

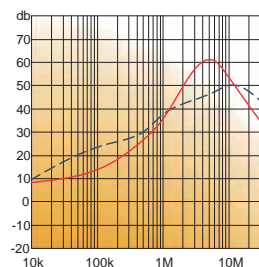

#### ■ 8A~10A

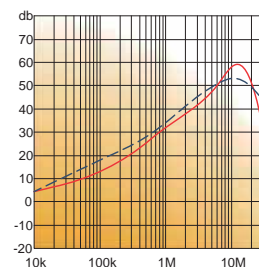

Common mode / Asymmetric (L-G) ————  
 Differential mode / Symmetric (L-L) - - - - -

## Filter Selection Table •

Filter Part No.	Rated Current @50°C [A]	Leakage Current @250VAC/50Hz [µA]	Inductance @10KHz,0.25V [mH]	Capacitance		
				Cx1 [µF]	Cx2 [µF]	Cy [nF]
<b>Blank: standard</b>						
01SS3-..S..	1	450	6.5	0.1	-	2.2
02SS3-..S..	2	450	3.8	0.1	-	2.2
04SS3-..S..	4	450	1.6	0.1	-	2.2
06SS3-..S..	6	450	0.8	0.1	-	2.2
10SS3-..S..	10	450	0.2	0.1	-	2.2
01SS3-..U..	1	100	11	0.1	-	0.47
02SS3-..U..	2	100	6.5	0.1	-	0.47
04SS3-..U..	4	100	4.2	0.1	-	0.47
06SS3-..U..	6	100	1.6	0.1	-	0.47
10SS3-..U..	10	100	0.4	0.1	-	0.47
<b>A: high performance</b>						
01SS3-A.S..	1	450	6.5	0.1	0.1	2.2
02SS3-A.S..	2	450	3.8	0.1	0.1	2.2
04SS3-A.S..	4	450	1.6	0.1	0.1	2.2
06SS3-A.S..	6	450	0.8	0.1	0.1	2.2
10SS3-A.S..	10	450	0.2	0.1	0.1	2.2
<b>A: medical compliance</b>						
01SS3A-..S..	1	5	6.5	0.1	-	-
02SS3A-..S..	2	5	3.8	0.1	-	-
04SS3A-..S..	4	5	1.6	0.1	-	-
06SS3A-..S..	6	5	0.8	0.1	-	-
10SS3A-..S..	10	5	0.2	0.1	-	-

## Output Terminal

(unit: mm)

- Q: fast-on tab based on UL310 standard

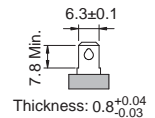

## Mechanical Drawing (unit: mm)

- screw mounting

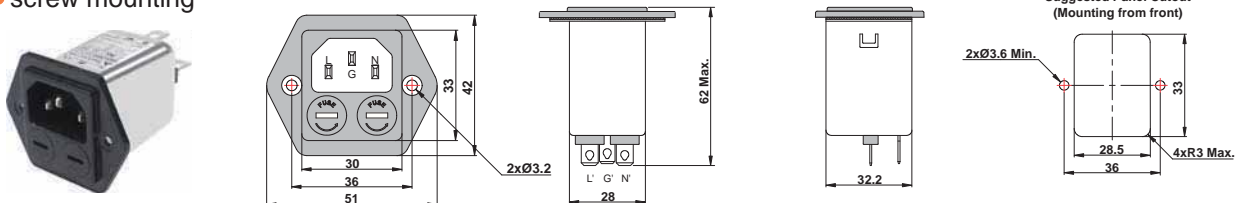

## Installation instructions for waterproof kit

- **Waterproof kit (Item code: Part x Q'ty)**

A1: Silicon rubber sealing for filter.....x1  
 A2: Silicon rubber sealing for fuse holder.....x6  
 A3: Silicon rubber sealing for M3 screw.....x6

A4: M3 screw.....x2  
 A5: M3 nut.....x2  
 A6: M3 washer.....x2

### ■ Step 1

Put A2 on the cover of fuse holder first. Install fuse(s) and put fuse holder back.

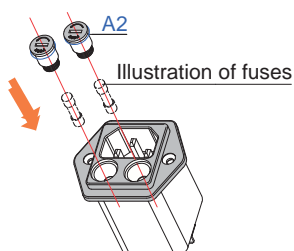

### ■ Step 2

Put A1 on the filter, then install the filter on panel.

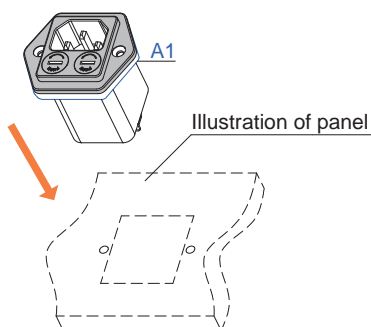

### ■ Step 3

Put A3 on A4 first, then install the A4. Install A6 and A5 on A4 from the rear of panel.

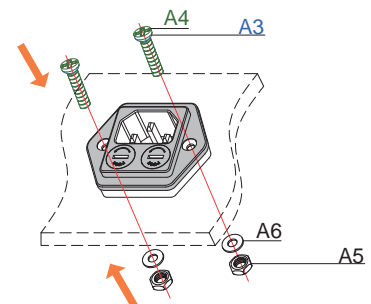

## Socket + Switch

### Features

- Standard conducted attenuation performance
- Optional SPST or DPST rocker switch
- Front mounting
- Current rating 1A~10A
- With IEC320 AC socket and switch

### Marketing Applications

- SMPS. UPS
- Power line communications
- Network technology
- Surveillance system
- EDP system

### Numbering System

**1** SS3 **2** - **3** S **4** **5** **6** **7** - **8** (**9**)

**1** Rated current

01,02,04,06,10

**2** Electrical schematic

**Blank:** standard

**A:** medical compliance, without Cy cap.

**3** Additional schematic (optional)

**A:** high performance

**4** Type of case (refer P16 Mechanical drawing)

**Blank:** screw mounting

**P:** snap-in mounting with up & down spring

**5** Components value (refer P16 Filter selection table)

**S:** Cx=0.1uF, Cy=2.2nF

**U:** Cx=0.1uF, Cy=0.47nF

**6** Grounded choke (optional)

**G:** Lg= 100uH

**7** Bleeder resistor (optional)

**R:** R= 1M ohm; 1/4W min.

**8** Output connections (refer P16 Output terminal)

**Q:** fast-on tab (6.3mm)

**W:** with wired (100mm)

**9** Type of switch

**B:** switch with black rocker

**R:** switch with illuminated red rocker, only for DPST switch

**G:** switch with illuminated green rocker, only for DPST switch

### Electrical Schematic •

• **Blank:** standard

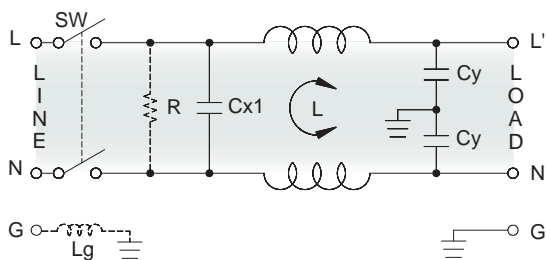

• **A:** high performance

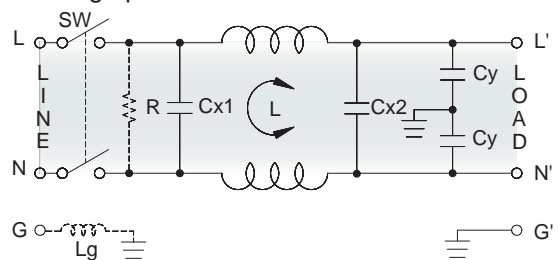

### Filter Attenuation Insertion loss (dB) in 50 ohm system CISPR 17 (for reference only)

■ 1A~3A

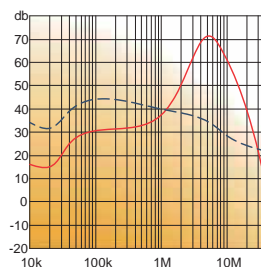

■ 4A~6A

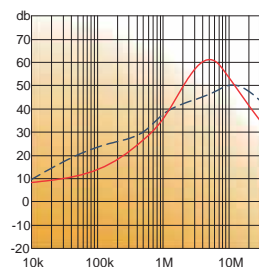

■ 8A~10A

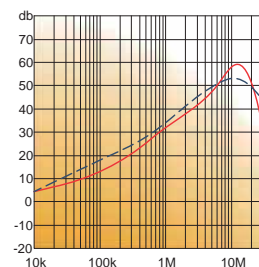

Common mode / Asymmetric (L-G) ————  
Differential mode / Symmetric (L-L) - - - - -

## Filter Selection Table •

Filter Part No.	Rated Current @50°C [A]	Leakage Current @250VAC/50Hz [µA]	Inductance @10KHz,0.25V [mH]	Capacitance			Output terminal	
				Cx1 [µF]	Cx2 [µF]	Cy [nF]		
<b>Blank: standard</b>								
01SS3-..S..	1	450	6.5	0.1	-	2.2	-Q	-W
02SS3-..S..	2	450	3.8	0.1	-	2.2	-Q	-W
04SS3-..S..	4	450	1.6	0.1	-	2.2	-Q	-W
06SS3-..S..	6	450	0.8	0.1	-	2.2	-Q	-W
10SS3-..S..	10	450	0.2	0.1	-	2.2	-Q	-W
01SS3-..U..	1	100	11	0.1	-	0.47	-Q	-W
02SS3-..U..	2	100	6.5	0.1	-	0.47	-Q	-W
04SS3-..U..	4	100	4.2	0.1	-	0.47	-Q	-W
06SS3-..U..	6	100	1.6	0.1	-	0.47	-Q	-W
10SS3-..U..	10	100	0.4	0.1	-	0.47	-Q	-W
<b>A: high performance</b>								
01SS3-A.S..	1	450	6.5	0.1	0.1	2.2	-Q	-W
02SS3-A.S..	2	450	3.8	0.1	0.1	2.2	-Q	-W
04SS3-A.S..	4	450	1.6	0.1	0.1	2.2	-Q	-W
06SS3-A.S..	6	450	0.8	0.1	0.1	2.2	-Q	-W
10SS3-A.S..	10	450	0.2	0.1	0.1	2.2	-Q	-W
<b>A: medical compliance</b>								
01SS3A-..S..	1	5	6.5	0.1	-	-	-Q	-W
02SS3A-..S..	2	5	3.8	0.1	-	-	-Q	-W
04SS3A-..S..	4	5	1.6	0.1	-	-	-Q	-W
06SS3A-..S..	6	5	0.8	0.1	-	-	-Q	-W
10SS3A-..S..	10	5	0.2	0.1	-	-	-Q	-W

## Output Terminal

(unit: mm)

- **Q:** fast-on tab based on UL310 standard

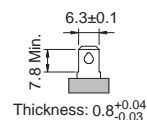

- **W:** with wired stripped and tinned

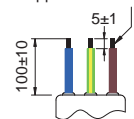

## Mechanical Drawing (unit: mm) •

- **Blank:** screw mounting, with DPST switch

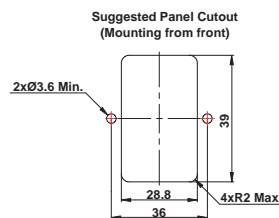
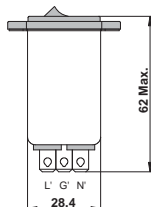
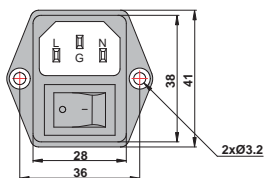

- **Blank:** screw mounting, with SPST switch

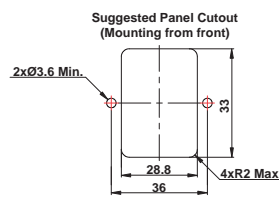
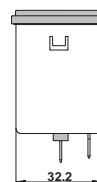
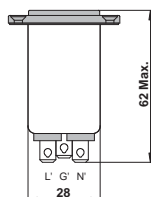
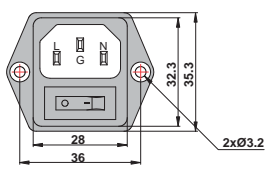

- **Blank:** screw mounting, with DPST switch

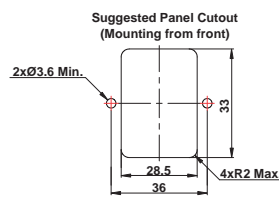
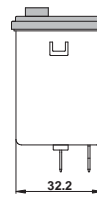
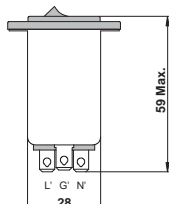
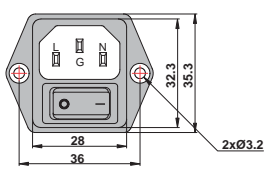

- **P:** snap-in mounting, with DPST switch

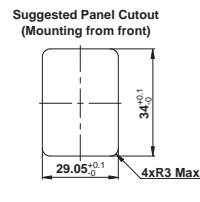
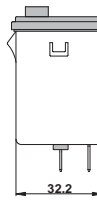
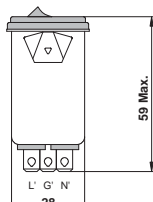
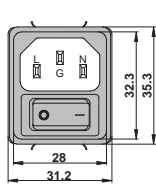

• Please call for alternatives

# POWER ENTRY MODULE

## Socket + Fuse holder + Switch

### Features

- 3 in 1 compact power entry modules with filtered
- IEC950 appliance inlet
- Front mounting or snap-in mounting
- Current rating 1A~10A
- With IEC320 AC socket and fuse holder and switch

### Marketing Applications

- Safety tester
- Automated optical inspection (AOI)
- Gaming machine
- Darts machine
- Server

### Numbering System

1 SS6 2 - 3 4 5 6 7 - 8 9 10

1 Rated current

01,02,04,06,10

2 Electrical schematic (optional)

A: medical compliance, without Cy cap.

3 Type of module

B1: socket + switch + single fuse holder  
B2: socket + switch + double fuse holders

4 Electrical schematic

A: general purpose; B: high performance

5 Components value (refer P18 Filter selection table)

H: Cx=0.22uF, Cy=2.2nF  
I: Cx=0.22uF, Cy=3.3nF

6 Grounded choke (optional)

G: Lg= 400uH

7 Bleeder resistor (optional)

R: R= 1M ohm; 1/4W min.

8 Output connections (refer P18 Output terminal)

Q: fast-on tab (6.3mm)

9 Type of case (refer P18 Mechanical drawing)

B,P,U

10 Type of switch

B: switch with black rocker  
R: switch with illuminated red rocker  
G: switch with illuminated green rocker

### Electrical Schematic •

• A: standard

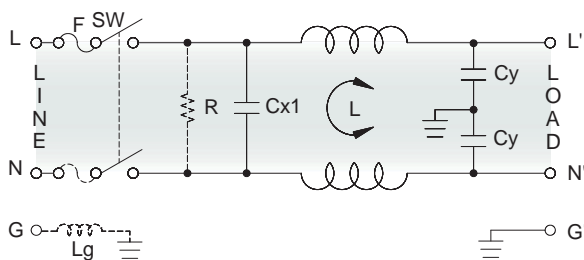

• B: high performance

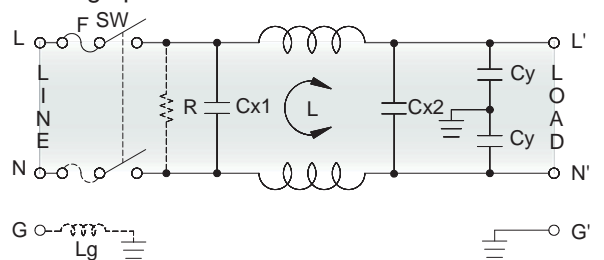

### Filter Attenuation Insertion loss (dB) in 50 ohm system CISPR 17 (for reference only)

1A~3A

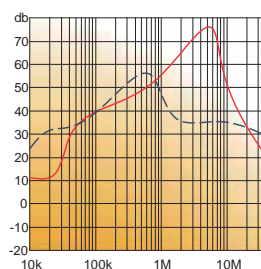

4A~6A

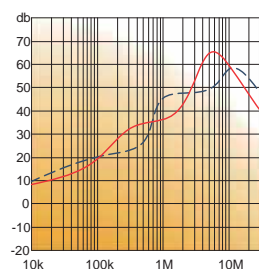

8A~10A

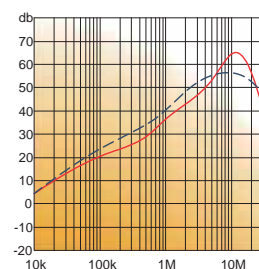

Common mode / Asymmetric (L-G) ————  
Differential mode / Symmetric (L-L) - - - - -

## Filter Selection Table •

Filter Part No.	Rated Current @50°C [A]	Leakage Current @250VAC/50Hz [µA]	Inductance @10KHz,0.25V [mH]	Capacitance		
				Cx1 [µF]	Cx2 [µF]	Cy [nF]
<b>A: standard</b>						
01SS6-.AH...Q..	1	450	7.5	0.22	-	2.2
02SS6-.AH...Q..	2	450	5.5	0.22	-	2.2
04SS6-.AH...Q..	4	450	2	0.22	-	2.2
06SS6-.AH...Q..	6	450	0.8	0.22	-	2.2
10SS6-.AH...Q..	10	450	0.4	0.22	-	2.2
01SS6-.AI...Q..	1	600	10	0.22	-	3.3
02SS6-.AI...Q..	2	600	6.5	0.22	-	3.3
04SS6-.AI...Q..	4	600	2.7	0.22	-	3.3
06SS6-.AI...Q..	6	600	1.05	0.22	-	3.3
10SS6-.AI...Q..	10	600	0.4	0.22	-	3.3
<b>B: high performance</b>						
01SS6-.BH...Q..	1	450	7.5	0.22	0.22	2.2
02SS6-.BH...Q..	2	450	5.5	0.22	0.22	2.2
04SS6-.BH...Q..	4	450	2	0.22	0.22	2.2
06SS6-.BH...Q..	6	450	0.8	0.22	0.22	2.2
10SS6-.BH...Q..	10	450	0.4	0.22	0.22	2.2
<b>A: medical compliance</b>						
01SS6A-.AH...Q..	1	5	7.5	0.22	-	-
02SS6A-.AH...Q..	2	5	5.5	0.22	-	-
04SS6A-.AH...Q..	4	5	2	0.22	-	-
06SS6A-.AH...Q..	6	5	0.8	0.22	-	-
10SS6A-.AH...Q..	10	5	0.4	0.22	-	-

## Output Terminal

(unit: mm)

- Q: fast-on tab based on UL310 standard

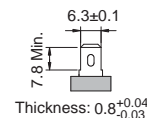

## Mechanical Drawing (unit: mm) ••

- B: screw mounting with left & right ear

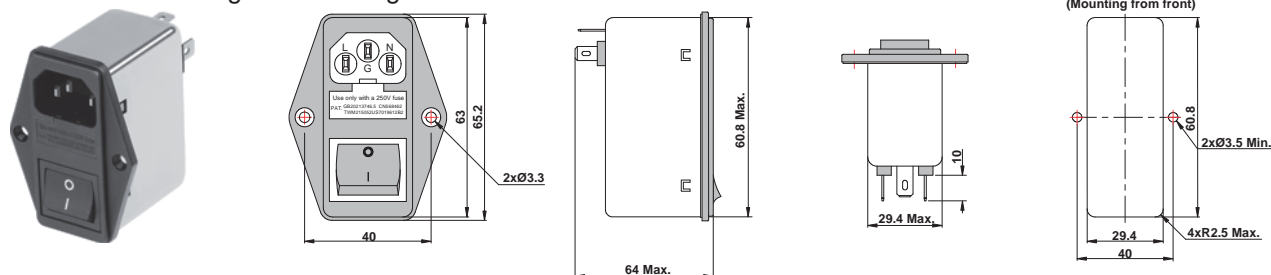

- P: snap-in mounting with up & down spring

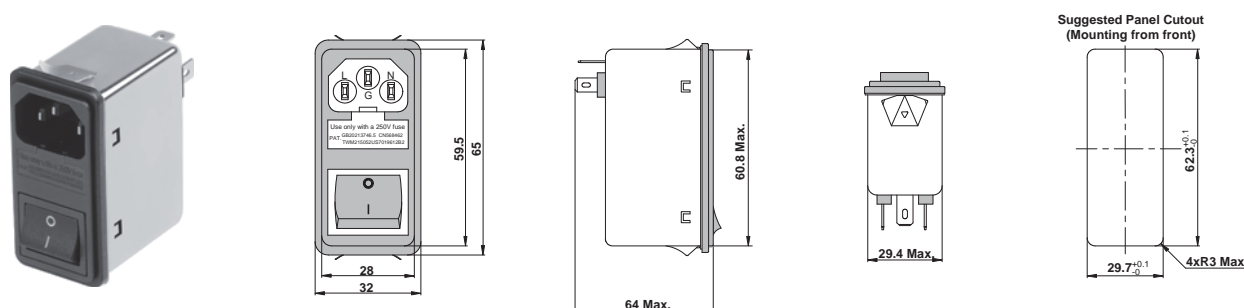

- U: screw mounting with up & down ear

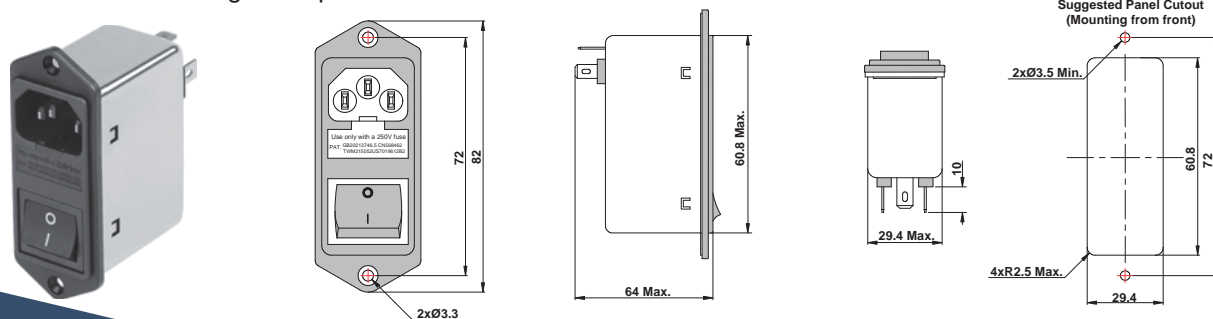

• Refer P55 for the installation instructions for fuse. • Please call for alternatives



# SINGLE PHASE FILTER

Metal Chassis

## General Purpose

### Features

- Standard conducted attenuation performance
- Single stage power line filter
- Current rating 1A~30A
- Various output connections
- Practical solution for general and medical devices

### Marketing Applications

- Single-phase power supplies
- Data storage
- Broadcast installations
- Network technology
- Medical device (not body-coupled)

### Numbering System

**1** SS4 **2** - **3** **4** - **5** **6** - **7**

**1** Rated current

01,03,06,10,15,20,30

**2** Additional schematic (optional)

A: medical compliance, without Cy cap.

**3** Electrical schematic

**1A:** combined with **5** Cx=0.1uF, Cy=3.3nF

**1B:** combined with **5** Cx=0.22uF, Cy=3.3nF

**4** Type of case (refer P20 Mechanical drawing)

**A1~A3:** only for 1~20A

**B1:** only for 10~30A

**C2:** only for 6~30A

**G1:** only for 10~30A

**5** Components value (refer P20 Filter selection table)

**B:** Cx=0.1uF, Cy=3.3nF

**Blank:** Cx=0.22uF, Cy=3.3nF

**6** Bleeder resistor (optional, refer P20 Filter selection table)

R

**7** Output connections (refer P20 Output terminal)

**Q:** fast-on tab (6.3mm)

**S:** screw (M4)

**W:** with wired (100mm)

### Electrical Schematic

● **1A**

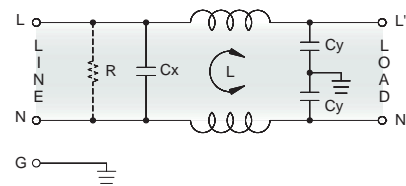

● **1B**

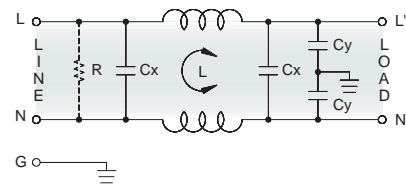

### Filter Attenuation

Insertion loss (dB) in 50 ohm system CISPR 17 (for reference only)

■ **1A~3A**

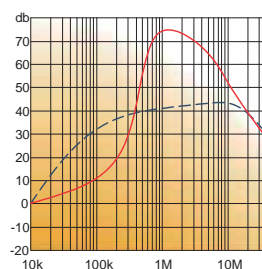

■ **6A~10A**

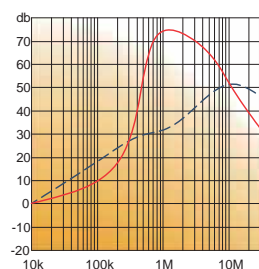

■ **15A~20A**

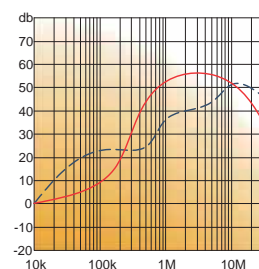

■ **30A**

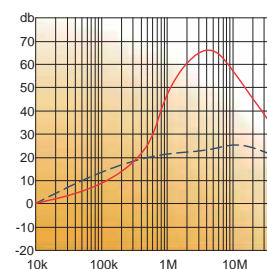

Common mode / Asymmetric (L-G) ————  
 Differential mode / Symmetric (L-L) - - - - -

## Filter Selection Table •

Filter Part No.	Rated Current @50°C [A]	Leakage Current @250VAC/50Hz [µA]	Inductance @10KHz,0.25V [mH]	Capacitance		Resistor R [Ω]	Output terminal		
				Cx [µF]	Cy [nF]				
<b>1A:</b>									
01SS4-1AA1-B.	1	600	10	0.1	3.3	1M	-Q	-	-W
03SS4-1AA1-B.	3	600	1.2	0.1	3.3	1M	-Q	-	-W
06SS4-1AA2-B.	6	600	0.8	0.1	3.3	1M	-Q	-S	-W
10SS4-1AA2-B.	10	600	1	0.1	3.3	1M	-Q	-S	-W
15SS4-1AA3-B.	15	600	0.9	0.1	3.3	1M	-Q	-S	-W
20SS4-1AA3-B.	20	600	0.7	0.1	3.3	1M	-Q	-S	-W
30SS4-1AA3-B.	30	600	0.3	0.1	3.3	1M	-Q	-S	-W
<b>1B:</b>									
01SS4-1BA2-.	1	600	10	0.22	3.3	2.2M	-Q	-S	-W
03SS4-1BA3-.	3	600	8	0.22	3.3	2.2M	-Q	-S	-W
06SS4-1BA3-.	6	600	2	0.22	3.3	2.2M	-Q	-S	-W
10SS4-1BB1-.	10	600	1.5	0.22	3.3	2.2M	-Q	-S	-W
15SS4-1BC2-.	15	600	2	0.22	3.3	2.2M	-Q	-S	-
20SS4-1BC2-.	20	600	0.9	0.22	3.3	2.2M	-Q	-S	-
30SS4-1BG1-.	30	600	1.5	0.22	3.3	2.2M	-Q	-S	-
<b>1A: medical compliance</b>									
01SS4A-1AA1-B.	1	5	10	0.1	-	1M	-Q	-	-W
03SS4A-1AA1-B.	3	5	1.2	0.1	-	1M	-Q	-	-W
06SS4A-1AA2-B.	6	5	0.8	0.1	-	1M	-Q	-S	-W
10SS4A-1AA2-B.	10	5	1	0.1	-	1M	-Q	-S	-W
15SS4A-1AA3-B.	15	5	0.9	0.1	-	1M	-Q	-S	-W
20SS4A-1AA3-B.	20	5	0.7	0.1	-	1M	-Q	-S	-W
30SS4A-1AA3-B.	30	5	0.3	0.1	-	1M	-Q	-S	-W

## Mechanical Drawing (unit: mm) •

• A

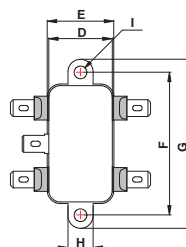
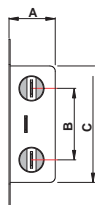

• B1

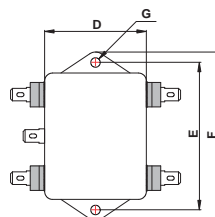
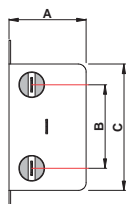

• C2

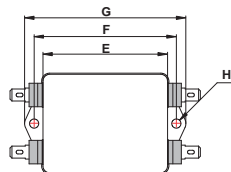
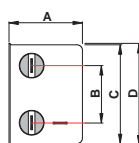

• G1

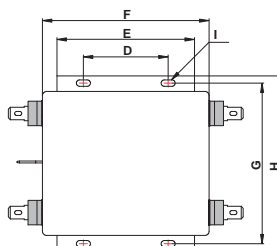
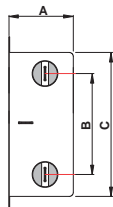

Case	A1	A2	A3
A	17.5	30	30
B	27	21.2	28.1
C	44	43.5	52
D	24	32.5	46
E	26	35	48
F	54.1	54	61
G	64.5	64	71
H	9.5	10	10
I	2-Ø4.8	2-Ø5.3x6.3	

Case	B1
A	39.5
B	42.3
C	65.5
D	52.5
E	74.7
F	84.8
G	2-Ø4.8

Case	C2
A	39.5
B	30
C	52.5
D	54
E	65.5
F	74.7
G	84.8
H	2-Ø4.8

Case	G1
A	38.6
B	48.5
C	83.6
D	51
E	79
F	98
G	96.5
H	105
I	4-Ø4x6.5

## Output Terminal

(unit: mm)

- Q: fast-on tab based on UL310 standard

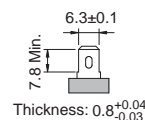

- S: screw based on ISO4032 standard

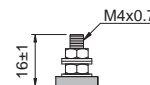

- W: with wired stripped and tinned

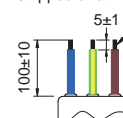

# SINGLE PHASE FILTER

Metal Chassis

## High Performance

### Features

- Superior conducted attenuation performance
- Double stage power line filter
- Current rating 1A~20A
- Various output connections
- Practical solution for general and medical devices

### Marketing Applications

- Small household & Living appliances
- Energy management system
- Food processing equipment
- Automatic data processing system
- Automation

### Numbering System

**1** SS4 **2** - **3** **4** - **5**

**1** Rated current

01,03,06,10,15,20

**2** Additional schematic (optional)

A: medical compliance, without Cy cap.

**3** Electrical schematic

2D: combined with components value  $C_x=0.1\mu\text{F}$ ,  $C_y=3.3\text{nF}$

2F,2G: combined with components value  $C_x=0.22\mu\text{F}$ ,  $C_y=4.7\text{nF}$

**4** Type of case (refer P22 Mechanical drawing)

C1,C2

**5** Output connections (refer P22 Output terminal)

Q: fast-on tab (6.3mm)

S: screw (M4)

W: with wired (100mm)

### Electrical Schematic

● 2D

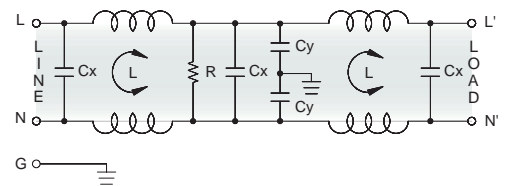

● 2F

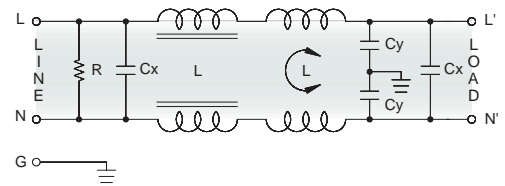

● 2G

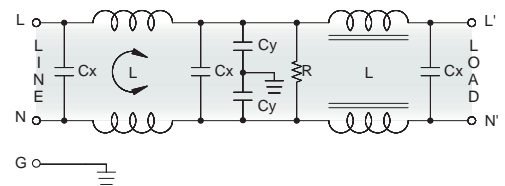

### Filter Attenuation

Insertion loss (dB) in 50 ohm system CISPR 17 (for reference only)

■ 1A~3A

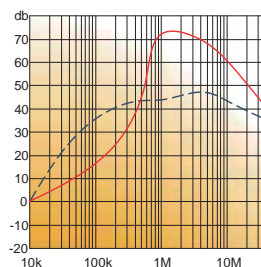

■ 6A~10A

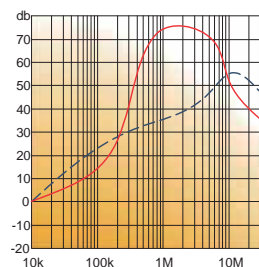

■ 15A~20A

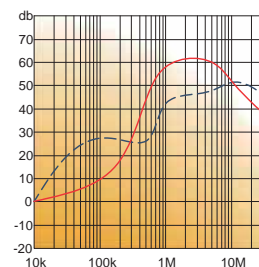

Common mode / Asymmetric (L-G) ————  
Differential mode / Symmetric (L-L) - - - - -

## Filter Selection Table ●

Filter Part No.	Rated Current @50°C [A]	Leakage Current @250VAC/50Hz [μA]	Inductance @10KHz,0.25V		Capacitance		Resistor R [Ω]	Output terminal		
			[mH]	[uH]	Cx [uF]	Cy [nF]				
<b>2D:</b>										
01SS4-2DC1-	1	600	3.7	-	0.1	3.3	2.2M	-Q	-S	-W
03SS4-2DC1-	3	600	1.8	-	0.1	3.3	2.2M	-Q	-S	-W
06SS4-2DC1-	6	600	0.7	-	0.1	3.3	2.2M	-Q	-S	-W
10SS4-2DC2-	10	600	0.3	-	0.1	3.3	2.2M	-Q	-S	-W
15SS4-2DC2-	15	600	0.9	-	0.1	3.3	2.2M	-Q	-S	-W
20SS4-2DC2-	20	600	0.5	-	0.1	3.3	2.2M	-Q	-S	-W
<b>2F:</b>										
03SS4-2FC1-	3	1000	1	30	0.22	4.7	330K	-Q	-S	-W
06SS4-2FC2-	6	1000	1.7	70	0.22	4.7	330K	-Q	-S	-W
10SS4-2FC2-	10	1000	1.2	40	0.22	4.7	330K	-Q	-S	-W
<b>2G:</b>										
03SS4-2GC1-	3	1000	1	30	0.22	4.7	330K	-Q	-S	-W
06SS4-2GC2-	6	1000	1.7	70	0.22	4.7	330K	-Q	-S	-W
10SS4-2GC2-	10	1000	1.2	40	0.22	4.7	330K	-Q	-S	-W
<b>2D: medical compliance</b>										
01SS4A-2DC1-	1	5	3.7	-	0.1	-	2.2M	-Q	-S	-W
03SS4A-2DC1-	3	5	1.8	-	0.1	-	2.2M	-Q	-S	-W
06SS4A-2DC1-	6	5	0.7	-	0.1	-	2.2M	-Q	-S	-W
10SS4A-2DC2-	10	5	0.3	-	0.1	-	2.2M	-Q	-S	-W
15SS4A-2DC2-	15	5	0.9	-	0.1	-	2.2M	-Q	-S	-W
20SS4A-2DC2-	20	5	0.5	-	0.1	-	2.2M	-Q	-S	-W

## Output Terminal

(unit: mm)

- **Q:** fast-on tab based on UL310 standard

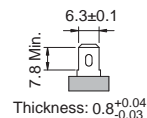

- **S:** screw based on ISO4032 standard

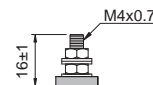

- **W:** with wired stripped and tinned

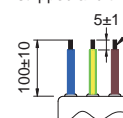

## Mechanical Drawing (unit: mm) ●

- **C**

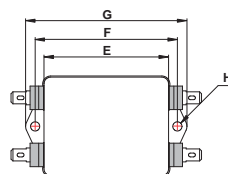
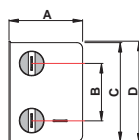

Case	C1	C2
A	30	39.5
B	22.4	30
C	46	52.5
D	48	54
E	52	65.5
F	61	74.7
G	71	84.8
H	2-Ø5.3x6.3	2-Ø4.8

# SINGLE PHASE FILTER

Metal Chassis

## Excellent Performance

### Features

- Ultra-high attenuation performance
- Multiple stage power line filter
- Current rating 1A~20A
- Various components value
- Ideal for industrial equipment

### Marketing Applications

- POS
- Packaging machine
- High power office equipment
- Measuring instruments
- Electronic data processing system

### Numbering System

**1** S4 - **2** **3** **4** - **5**

**1** Rated current

01,03,06,10,15,20

**2** Electrical schematic

3A,3B

**3** Components value

(refer P24 Filter selection table)

**4** Type of case

(refer P24 Mechanical drawing)

C4,C9

**5** Output connections

(refer P24 Output terminal)

**Q**: fast-on tab (6.3mm)

**S**: screw (M4)

### Electrical Schematic •

● 3A

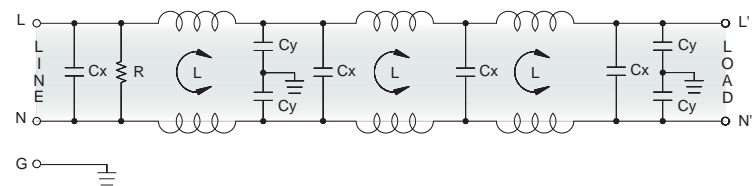

● 3B

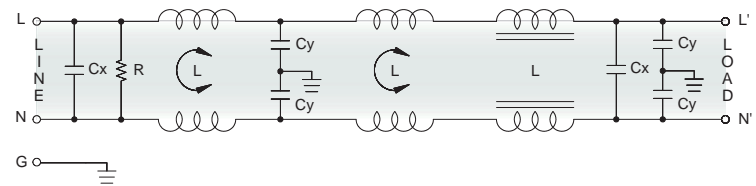

### Filter Attenuation

Insertion loss (dB) in 50 ohm system CISPR 17 (for reference only)

■ 1A~3A

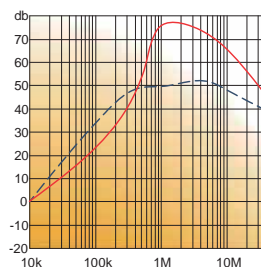

■ 6A~10A

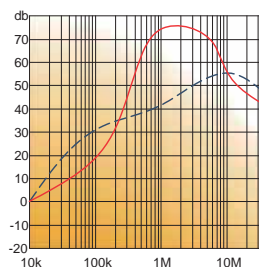

■ 15A~20A

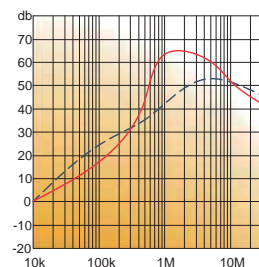

Common mode / Asymmetric (L-G) ————  
 Differential mode / Symmetric (L-L) - - - - -

## Filter Selection Table ●

Filter Part No.	Rated Current @50°C [A]	Leakage Current @ 250VAC/50Hz [μA]	Inductance @ 10KHz, 0.25V		Capacitance		Resistor R [Ω]	Output terminal	
			Σ[mH]	Σ[uH]	Cx Σ[uF]	Cy Σ[nF]			
<b>3A:</b>									
03S4-3A1054729.0474C9	3	2000	27	-	4	18.8	470K	-Q	-S
06S4-3A1054727.0474C9	6	2000	21	-	4	18.8	470K	-Q	-S
10S4-3A1054725.0474C9	10	2000	15	-	4	18.8	470K	-Q	-S
15S4-3A1054723.0474C9	15	2000	9	-	4	18.8	470K	-Q	-S
20S4-3A1054722.0474C9	20	2000	6	-	6	18.8	470K	-Q	-S
03S4-3A15547215.0474C4	3	2000	45	-	6	18.8	470K	-Q	-S
06S4-3A15547212.0474C4	6	2000	36	-	6	18.8	470K	-Q	-S
10S4-3A15547210.0474C4	10	2000	30	-	6	18.8	470K	-Q	-S
15S4-3A1554726.0474C4	15	2000	18	-	6	18.8	470K	-Q	-S
20S4-3A1554724.0474C4	20	2000	12	-	6	18.8	470K	-Q	-S
<b>3B:</b>									
03S4-3B2254729.0334C9	3	2000	18	300	4.4	18.8	330K	-Q	-S
06S4-3B2254727.0334C9	6	2000	14	200	4.4	18.8	330K	-Q	-S
10S4-3B2254725.0334C9	10	2000	10	100	4.4	18.8	330K	-Q	-S
15S4-3B2254723.0334C9	15	2000	6	60	4.4	18.8	330K	-Q	-S
20S4-3B2254722.0334C9	20	2000	4	30	4.4	18.8	330K	-Q	-S
03S4-3B33547215.0334C4	3	2000	30	300	6.6	18.8	330K	-Q	-S
06S4-3B33547212.0334C4	6	2000	24	200	6.6	18.8	330K	-Q	-S
10S4-3B33547210.0334C4	10	2000	20	100	6.6	18.8	330K	-Q	-S
15S4-3B3354726.0334C4	15	2000	12	60	6.6	18.8	330K	-Q	-S
20S4-3B3354724.0334C4	20	2000	8	30	6.6	18.8	330K	-Q	-S

## Output Terminal

(unit: mm)

- **Q:** fast-on tab based on UL310 standard

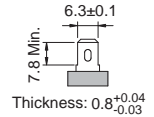

- **S:** screw based on ISO4032 standard

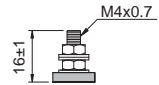

## Mechanical Drawing (unit: mm) ●

- **C4**

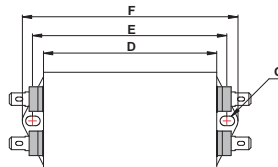
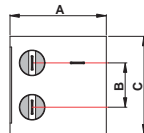

Case	C4
A	69.8
B	25
C	50.6
D	133.5
E	142.5
F	152.5
G	2-Ø5x6.35

- **C9**

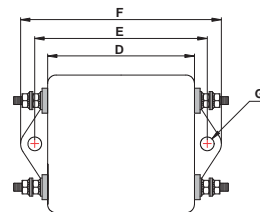
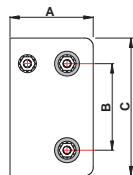

Case	C9
A	50
B	23
C	52
D	90
E	101
F	112
G	2-Ø5x7.5

# SINGLE PHASE FILTER

Plastic Chassis

## General Purpose

### Features

- Superior attenuation of common-mode noise
- Light weight plastic housing design
- Current rating 1A~30A
- Integrated nut is in hinged cover for reliable ring lug wiring
- Suitable for generally industrial applicaces

### Marketing Applications

- UPS
- Automated LED sorting machine
- Treadmill
- Building automation
- Automatic data processing system

### Electrical Schematic

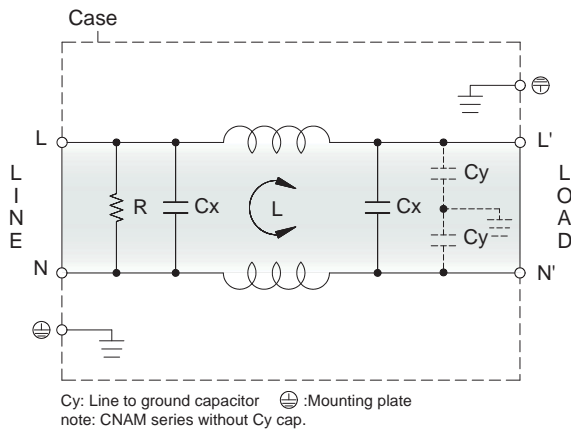

### Special Features

- CNAC series: best frequency bands from 150kHz~1MHz.
- CNAH series: best frequency bands from 10kHz~1MHz.
- CNAP series: high-voltage pulses.
- CNAM series: medical grade with very low leakage current.

### Technical Data and Measuring Conditions

No.	■ CNAC series Filter PRJ No.	01CNAC472	03CNAC472	06CNAC472	10CNAC472	15CNAC472	20CNAC472	30CNAC472	
	■ CNAH series Filter PRJ No.	01CNAH472	03CNAH472	06CNAH472	10CNAH472	15CNAH472	20CNAH472	30CNAH472	
	■ CNAP series Filter PRJ No.	01CNAP472	03CNAP472	06CNAP472	10CNAP472	15CNAP472	20CNAP472	30CNAP472	
	■ CNAM series Filter PRJ No.	01CNAM000	03CNAM000	06CNAM000	10CNAM000	15CNAM000	20CNAM000	30CNAM000	
1	Rated voltage	AC 1∅ 250V / DC250V							
2	Rated current	1A	3A	6A	10A	15A	20A	30A	
3	Test voltage	2,500 VAC (Cutoff current: 20mA), 1 min. at room temperature and humidity							
4	Isolation resistance	500VDC 100MΩ min. at room temperature and humidity							
5	Leakage current	CNAC / CNAH / CNAP series: 1mA; CNAM series: 5μA @250VAC/60Hz (max.)							
6	Cy cap. value ●	0 ~ 0.47nF							
7	Voltage drop	1.0V max.							
8	Safety approval temp.	-25° ~ +100°							
9	Operating temperature	-40° ~ +100°							
10	Operating humidity	20 ~ 95%RH (Non condensing)							
11	Storage temp. / humidity	-40° ~ +100°; 20 ~ 95%RH (Non condensing)							
12	Vibration	10 ~ 55Hz, 19.6m/s <sup>2</sup> (2G), 3 min. period, 1 hour each X,Y,Z axis							
13	Impact	196.1m/s <sup>2</sup> (20G), 11ms, once along X,Y,Z axis							
14	Safety approvals	UL1283, CSA C22.2 No.8 (C-UL), VDE0565 Teil3-1, IEC/EN60939							

## Mechanical Drawing (unit: mm)

### ● Chassis mounting

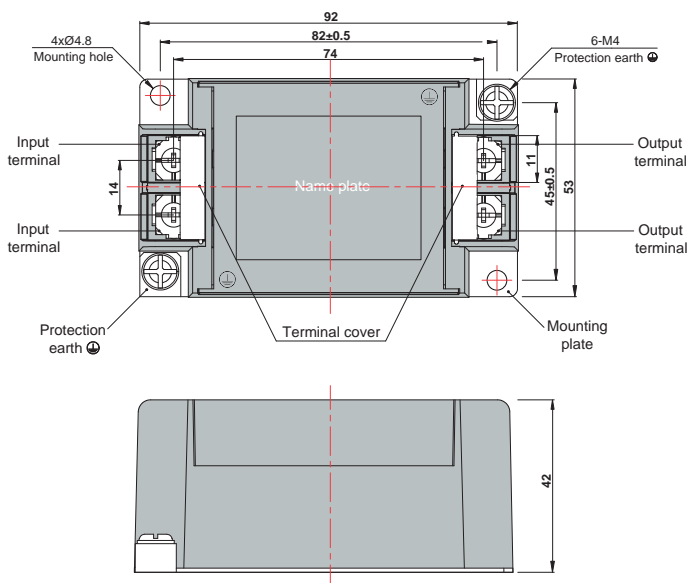

- ※ Tolerance: ±1
- ※ Case: PC
- ※ Mounting plate: Iron (surface finishing: nickel plating) t= 1.2
- ※ Terminal block screw tightening torque M4: 1.6N·m (16.9kgf·cm) max.

### ● DIN-rail mounting

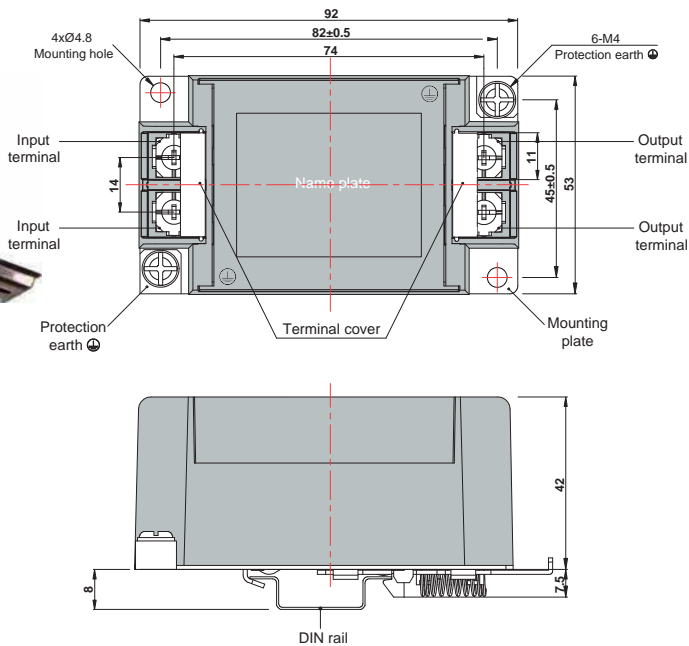

- ※ Tolerance: ±1
- ※ Case: PC
- ※ Mounting plate: Iron (surface finishing: nickel plating) t= 1.2
- ※ Terminal block screw tightening torque M4: 1.6N·m (16.9kgf·cm) max.

### Note when installing the EMI filter on a DIN rail:

When the EMI filter is grounded through the DIN rail, the proper noise attenuation may not be achieved. Be sure to connect the protection earth (PE) of the EMI filter body to the earth.

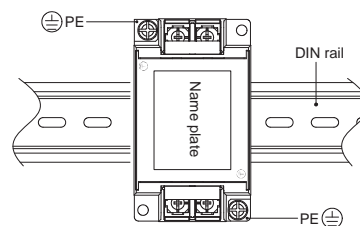



# SINGLE PHASE FILTER

Plastic Chassis

## High Performance

### Features

- Premium attenuation of common-mode noise
- Light weight, small size plastic housing design
- Current rating 1A~30A
- Integrated nut is in hinged cover for reliable ring lug wiring
- Widely used in SMPS

### Marketing Applications

- SMPS
- Ultrasonic welding machine
- Electric appliance cabinet
- Medical device (not body-coupled)
- High power office equipment

### Electrical Schematic

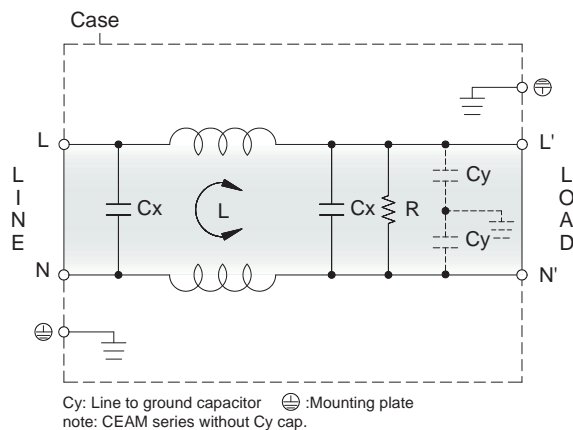

### Special Features

- CEAC series: best frequency bands from 150kHz~1MHz.
- CEAP series: high-voltage pulses.
- CEAM series: medical grade with very low leakage current.

### Technical Data and Measuring Conditions

No.	CEAC series Filter PRJ No.	01CEAC472	03CEAC472	06CEAC472	10CEAC472	15CEAC472	20CEAC472	30CEAC472	
	CEAP series Filter PRJ No.	01CEAP472	03CEAP472	06CEAP472	10CEAP472	15CEAP472	20CEAP472	30CEAP472	
	CEAM series Filter PRJ No.	01CEAM000	03CEAM000	06CEAM000	10CEAM000	15CEAM000	20CEAM000	30CEAM000	
1	Rated voltage	AC 1∅ 250V / DC250V							
2	Rated current	1A	3A	6A	10A	15A	20A	30A	
3	Test voltage	2,500 VAC (Cutoff current: 20mA), 1 min. at room temperature and humidity							
4	Isolation resistance	500VDC 100MΩ min. at room temperature and humidity							
5	Leakage current	CEAC / CEAP series: 1mA; CEAM series: 10μA @250VAC/60Hz (max.)							
6	Cy cap. value	0 ~ 0.47nF							
7	Voltage drop	1.0V max.							
8	Safety approval temp.	-25° ~ +100°							
9	Operating temperature	-40° ~ +100°							
10	Operating humidity	20 ~ 95%RH (Non condensing)							
11	Storage temp. / humidity	-40° ~ +100°; 20 ~ 95%RH (Non condensing)							
12	Vibration	10 ~ 55Hz, 19.6m/s <sup>2</sup> (2G), 3 min. period, 1 hour each X,Y,Z axis							
13	Impact	196.1m/s <sup>2</sup> (20G), 11ms, once along X,Y,Z axis							
14	Safety approvals	UL1283, CSA C22.2 No.8 (C-UL), VDE0565 Teil3-1, IEC/EN60939							

## Mechanical Drawing (unit: mm)

### ● Chassis mounting

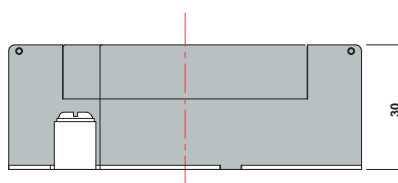
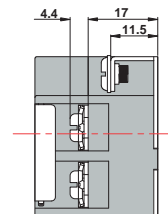
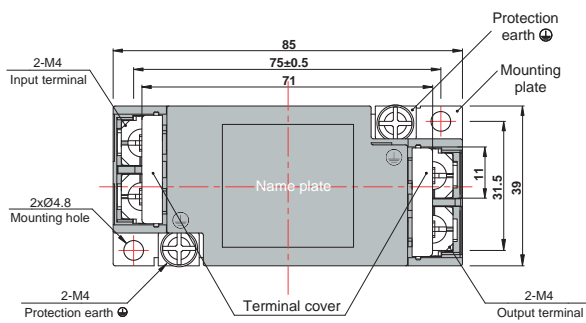

- ※ Tolerance:  $\pm 1$
- ※ Case: PC
- ※ Mounting plate: Iron  
(surface finishing: nickel plating)  $t= 1.0$
- ※ Terminal block screw tightening torque  
M4: 1.6N-m (16.9kgf-cm) max.

# SINGLE PHASE FILTER

Plastic Chassis

## High Performance

### Features

- Superior attenuation of common-mode noise
- 2-stage filter suitable for heavily noisy environment
- Current rating 1A~20A
- Integrated nut is in hinged cover for reliable ring lug wiring
- Light weight plastic housing design

### Marketing Applications

- Metal processing equipment
- Automation
- Assembly lines
- Computer numerical control (CNC)
- Packaging machine

### Electrical Schematic

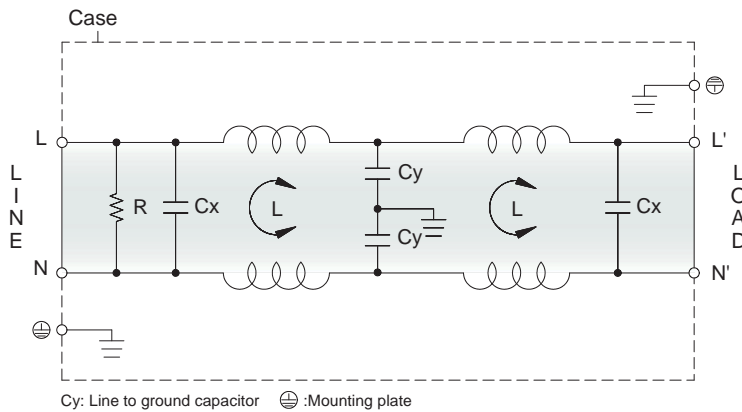

### Special Features

- CNBC series: best frequency bands from 150kHz~1MHz.
- CNBM series: with very low leakage current; withstand voltage 4,000VAC.

### Technical Data and Measuring Conditions

No.	CNBC series Filter PRJ No.	01CNBC472	03CNBC472	06CNBC472	10CNBC472	15CNBC472	20CNBC472
	CNBM series Filter PRJ No.	01CNBM471	03CNBM471	06CNBM471	10CNBM471	15CNBM471	20CNBM471
1	Rated voltage	AC 1Ø 250V / DC250V					
2	Rated current	1A	3A	6A	10A	15A	20A
3	Test voltage	CNBC series: 2,500 VAC; CNBM series: 4,000 VAC (Cutoff current: 20mA), 1 min. at room temperature and humidity					
4	Isolation resistance	500VDC 100MΩ min. at room temperature and humidity					
5	Leakage current	CNBC series: 1mA; CNBM series: 100µA @250VAC/60Hz (max.)					
6	Cy cap. value	0.047 ~ 0.47nF					
7	Voltage drop	1.0V max.					
8	Safety approval temp.	-25° ~ +100°					
9	Operating temperature	-40° ~ +100°					
10	Operating humidity	20 ~ 95%RH (Non condensing)					
11	Storage temp. / humidity	-40° ~ +100°; 20 ~ 95%RH (Non condensing)					
12	Vibration	10 ~ 55Hz, 19.6m/s <sup>2</sup> (2G), 3 min. period, 1 hour each X,Y,Z axis					
13	Impact	196.1m/s <sup>2</sup> (20G), 11ms, once along X,Y,Z axis					
14	Safety approvals	UL1283, CSA C22.2 No.8 (C-UL), VDE0565 Teil3-1, IEC/EN60939					

## Mechanical Drawing (unit: mm)

### ● Chassis mounting

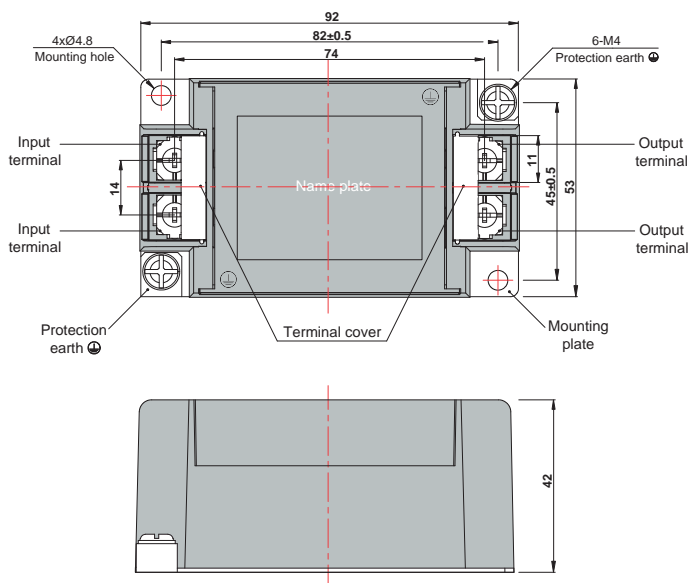

- ※ Tolerance: ±1
- ※ Case: PC
- ※ Mounting plate: Iron (surface finishing: nickel plating) t= 1.2
- ※ Terminal block screw tightening torque M4: 1.6N·m (16.9kgf·cm) max.

### ● DIN-rail mounting

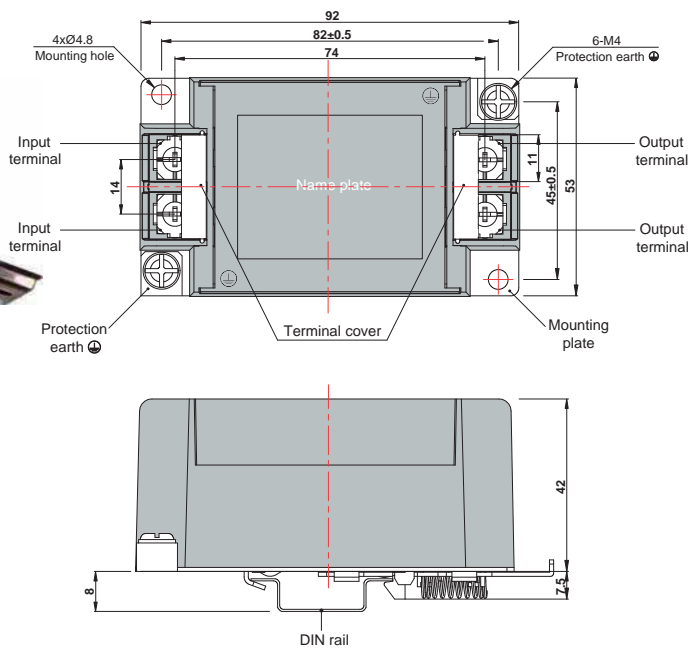

- ※ Tolerance: ±1
- ※ Case: PC
- ※ Mounting plate: Iron (surface finishing: nickel plating) t= 1.2
- ※ Terminal block screw tightening torque M4: 1.6N·m (16.9kgf·cm) max.

### Note when installing the EMI filter on a DIN rail:

When the EMI filter is grounded through the DIN rail, the proper noise attenuation may not be achieved. Be sure to connect the protection earth (PE) of the EMI filter body to the earth.

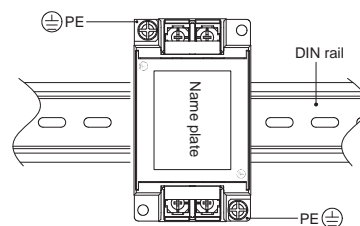

# HOME APPLIANCE FILTER

## General Purpose

### Features

- Good attenuation of differential and common mode noise
- Cylindrical can design
- Current rating 1A~16A
- Easy to install with stud or bracket for assembly
- Various mechanical dimension for different requirements

### Marketing Applications

- Washing machine. Dish washer
- Automatic coffee machine
- Blender. Fridge. Oven
- Extractor hood. Vacuum cleaner
- Vending machine

### Electrical Schematic

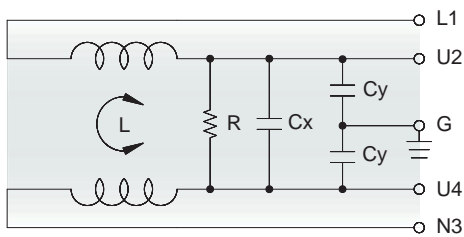

### Output Terminal (unit: mm)

- Q: fast-on tab based on UL310 standard

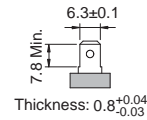

### Filter Selection Table

Filter Part No.	Rated Current @50°C [A]	Leakage Current @250VAC/50Hz [μA]	Inductance @10KHz, 0.25V [mH]	Capacitance		Resistor R [Ω]
				Cx [μF]	Cy [nF]	
10S7D-.1052732.0334-Q	10	5400	2	1	27	330K
10S7D-.4741030.5684-Q	10	2000	0.5	0.47	10	680K
10S7D-.1052732.0334-Q	10	5400	2	1	27	330K
10S7D-.1544720.5105-Q	10	1000	0.5	0.15	47	1M
16S7D-.4744721.0684-Q	16	1000	1	0.47	4.7	680K
16S7D-.1052731.0334-Q	16	5400	1	1	27	330K
16S7D-.4744721.0684-Q	16	1000	1	0.47	4.7	680K
16S7D-.4741031.0684-Q	16	2000	1	0.47	10	680K

### Filter Attenuation

Insertion loss (dB) in 50 ohm system CISPR 17 (for reference only)

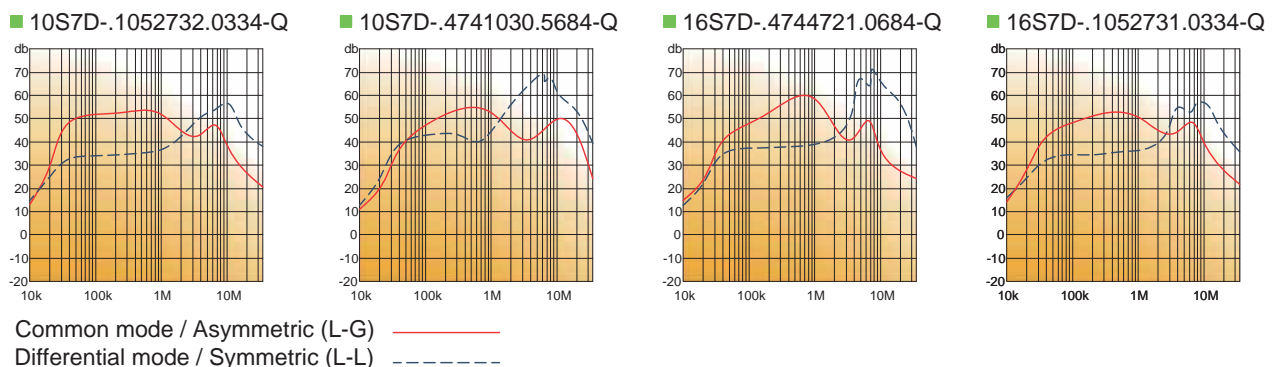

## Type of Case •

### • With stud

A1 case



A4 case



A14 case



D1 case



D4 case



D14 case



### • With bracket

B2 case



X3 case



J9 case



# PCB FILTER

## General Purpose

### Features

- General conducted attenuation performance
- SIP/DIP PCB filter
- Current rating 1A~20A
- With good HF coupling to the equipment housing
- Practical solution for general and medical devices

### Marketing Applications

- Surveillance system
- Test and measurement equipment
- Rack mounting equipment
- EDP and office equipment
- Medical device (not body-coupled)

### Electrical Schematic

#### ● 41AA1Q01 & 41AA1Q02

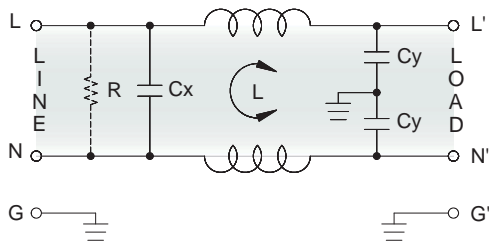

#### ● Medical compliance

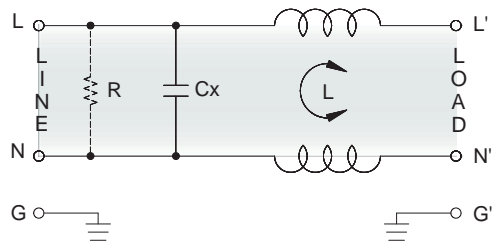

#### ● 42DC1S01

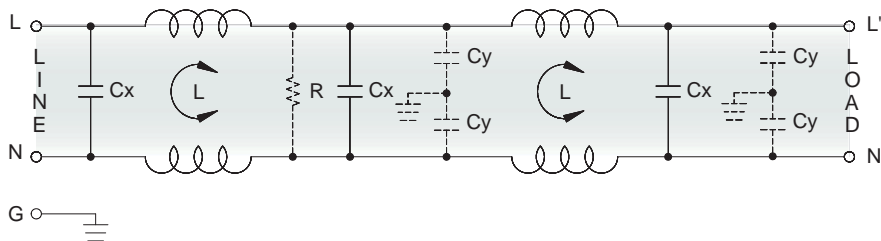

### Filter Attenuation

Insertion loss (dB) in 50 ohm system CISPR 17 (for reference only)

#### ■ 1A~3A

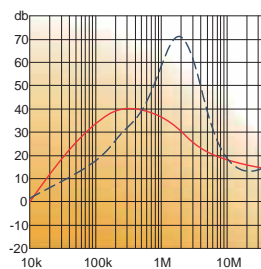

#### ■ 6A~10A

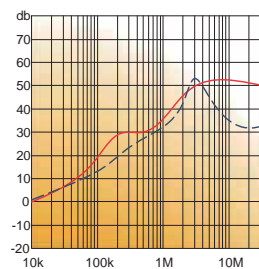

#### ■ 20A

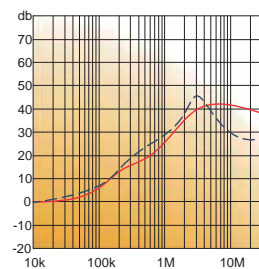

Common mode / Asymmetric (L-G) ————  
 Differential mode / Symmetric (L-L) - - - - -

## Filter Selection Table •

Filter Project No.	Rated Current @50°C [A]	Leakage Current @250VAC/50Hz [μA]	Inductance @10KHz,0.25V [mH]	Capacitance Cx [μF]	Cy [nF]
<b>41AA1Q01:</b>					
0141AA1Q01	1	450	10	0.1	2.2
0341AA1Q01	3	450	1.2	0.1	2.2
0641AA1Q01	6	450	0.8	0.1	2.2
1041AA1Q01	10	450	0.3	0.1	2.2
<b>42DC1S01:</b>					
0142DC1S01	1	1000	30	1	4.7
0342DC1S01	3	1000	15	1	4.7
0642DC1S01	6	1000	6	1	4.7
1042DC1S01	10	1000	4	1	4.7
1542DC2S01	15	1000	3	1	4.7
2042DC2S01	20	1000	2	1	4.7
<b>41AA1Q02:</b>					
0141AA1Q02	1	450	10	0.1	2.2
0341AA1Q02	3	450	1.2	0.1	2.2
0641AA1Q02	6	450	0.8	0.1	2.2
1041AA1Q02	10	450	0.3	0.1	2.2
<b>Medical compliance:</b>					
014A1AA1Q01	1	5	10	0.1	-
034A1AA1Q01	3	5	1.2	0.1	-
064A1AA1Q01	6	5	0.8	0.1	-
104A1AA1Q01	10	5	0.3	0.1	-

## Mechanical Drawing (unit: mm)

### • 41AA1Q01

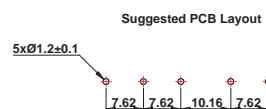
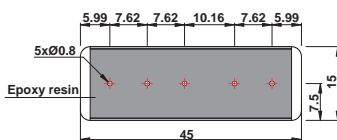
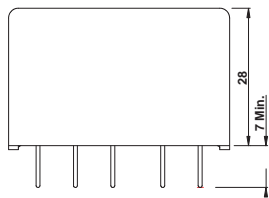

### • 42DC1S01

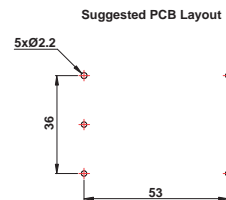
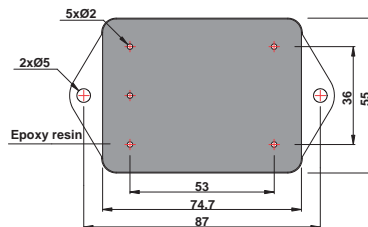
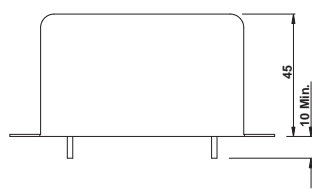

### • 41AA1Q02

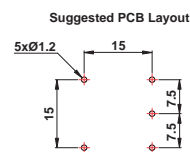
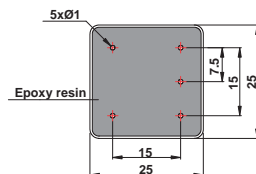
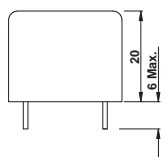



# 3 PHASE FILTER

## 3 Wired

### Features

- Excellent conducted attenuation performance
- Light weight metal housing design
- Current rating 7A~400A
- Extremely low leakage current values
- Touch-safe connections with hinged safety covers

### Marketing Applications

- HVAC system
- Motor driver
- Process control system
- Power management system
- Robotics

### Electrical Schematic

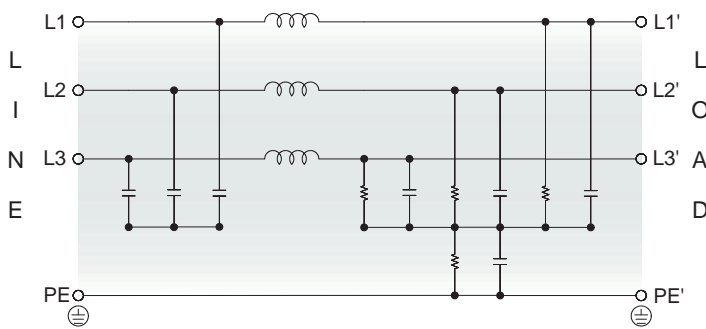

### Filter Selection Table •

Filter Project No.	Rated Current @50°C [A]	Typical Drive* Power Rating [kW]	Leakage Current** @400VAC/50Hz [mA]	Power Loss @25°C/50Hz [W]
07SCB58	7	4	33	3.8
08SCB58	8	4.5	33	4.0
10SCB58	10	5	33	4.5
16SCB58	16	7.5	33	6.1
20SCB58	20	10	33	7.8
25SCB58	25	13	33	10.5
30SCB58	30	15	33	11.8
36SCB58	36	20	33	13.8
40SCB58	40	21	33	14.8
42SCB58	42	22	33	15.7
50SCB58	50	28	33	21.5
55SCB58	55	30	33	25.9
60SCB58	60	32	33	28.5

\*Calculated at rated current, 600 VAC and  $\cos \phi = 0.8$ . The exact value depends upon the efficiency of the drive, the motor and the entire application.

\*\*Maximum leakage under normal operating conditions. Note: if two phases are interrupted, worst case leakage could reach 5.4 times higher levels.

### Filter Attenuation Insertion loss (dB) in 50 ohm system CISPR 17 (for reference only)

#### 7A~42A

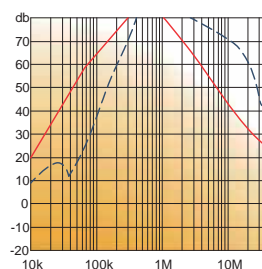

#### 50A~100A

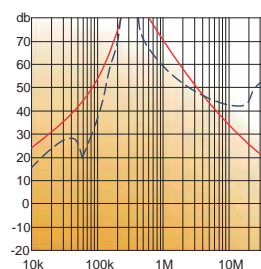

#### 130A

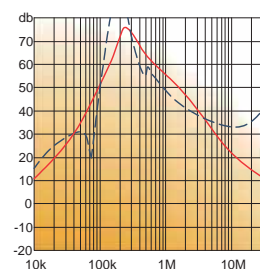

Common mode / Asymmetric (L-G) ————  
 Differential mode / Symmetric (L-L) - - - - -

## Mechanical Drawing

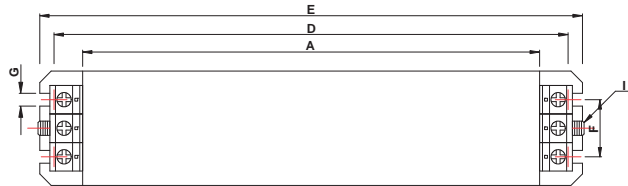
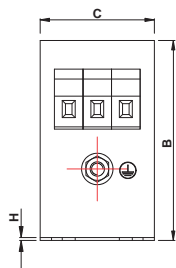

## Dimensions (unit: mm) Tolerances according to ISO 2768-m / EN 22768-m

Code	7~10A	16~20A	25~30A	36~42A	50~60A	75A	100A	130A
A	160	220	240	280	220	240	240	240
B	70	70	85	85	90	135	150	150
C	40	45	50	50	85	80	90	90
D	180	235	250	295	235	255	255	255
E	190	250	270	310	250	270	270	270
F	20	25	30	30	60	60	65	65
G	4.5	5.4	5.4	5.4	5.4	6.5	6.5	6.5
H	1	1	1	1	1	1.2	1.2	1.2
I	M5	M5	M5	M6	M6	M6	M10	M10

## Input / Output Terminal (unit: mm)

Terminal Cross Sections	7~16A	20~42A	50~75A	100~130A
Solid wire	10mm <sup>2</sup>	16mm <sup>2</sup>	35mm <sup>2</sup>	50mm <sup>2</sup>
Flex wire	6mm <sup>2</sup>	10mm <sup>2</sup>	25mm <sup>2</sup>	50mm <sup>2</sup>
AWG type wire	AWG 8	AWG 6	AWG 2	AWG 1/0
Recom. torque	1.5~1.8Nm	1.5~1.8Nm	4~4.5Nm	7~8Nm

# 3 PHASE FILTER

## 3 Wired

### Features

- Excellent conducted attenuation performance
- Light weight plastic housing design
- Current rating 10A~30A
- Extremely low leakage current values
- Optional DIN-Rail mounting

### Marketing Applications

- Stepping motor
- Electric appliance cabinet
- Smart grid
- AC servo motor
- Medical device (not body-coupled)

### Electrical Schematic

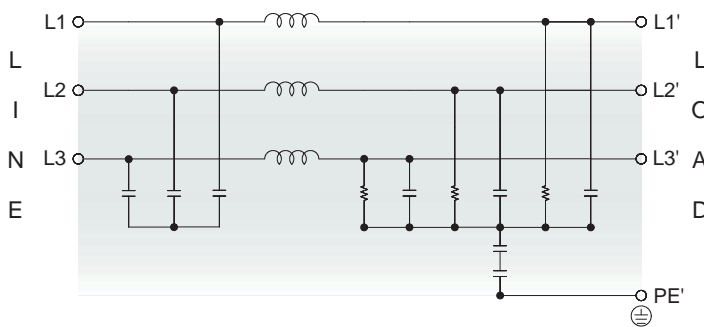

### Filter Selection Table •

Filter Project No.	Rated Current @50°C [A]	Typical Drive* Power Rating [kW]	Leakage Current** @480VAC/50Hz [mA]	Power Loss @25°C/50Hz [W]
10SCJ25L	10	5.5	0.4	4.8
20SCJ25L	20	11	0.4	5.2
30SCJ25L	30	18.5	0.4	7
10SCJ25P	10	5.5	2.5	4.8
20SCJ25P	20	11	2.5	5.2
30SCJ25P	30	18.5	2.5	7
10SCJ26L	10	5.5	0.4	4.8
20SCJ26L	20	11	0.4	5.2
30SCJ26L	30	18.5	0.4	7
10SCJ26P	10	5.5	2.5	4.8
20SCJ26P	20	11	2.5	5.2
30SCJ26P	30	18.5	2.5	7

\*Calculated at rated current, 480 VAC and cos phi = 0.8. The exact value depends upon the efficiency of the drive, the motor and the entire application.

\*\*Maximum leakage under normal operating conditions. Note: if two phases are interrupted, worst case leakage could reach 10 times higher levels.

### Filter Attenuation Insertion loss (dB) in 50 ohm system CISPR 17 (for reference only)

■ 10A~20A (L)

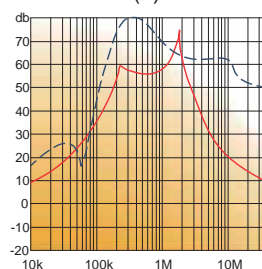

■ 10A~20A (P)

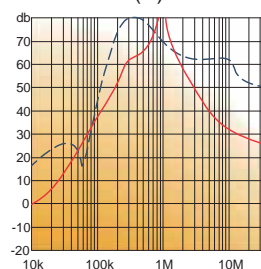

■ 30A (L)

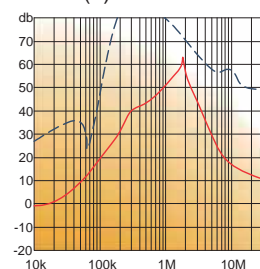

■ 30A (P)

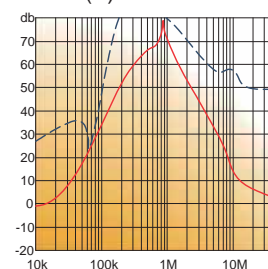

Common mode / Asymmetric (L-G) ————  
Differential mode / Symmetric (L-L) - - - - -

## Mechanical Drawing

### ● SCJ25: Chassis mounting

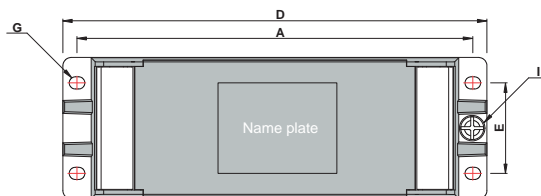
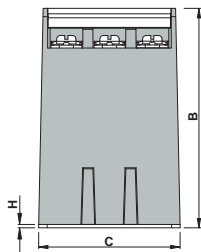

### ● SCJ26: DIN-rail mounting

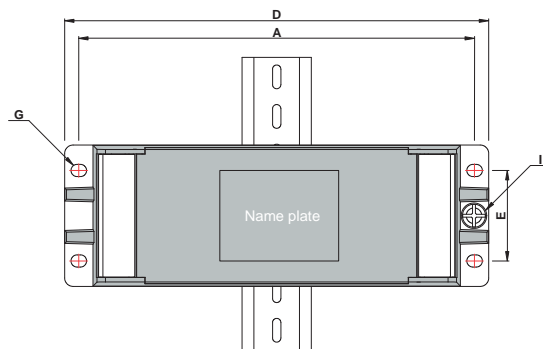
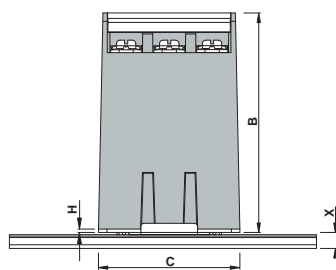

## Dimensions (unit: mm)

Tolerances according to ISO 2768-m / EN 22768-m

Code	10A	20A	30A
A	140	140	140
B	78	78	78
C	50	50	50
D	150	150	150
E	32	32	32
G	4.3x5.5	4.3x5.5	4.3x5.5
H	1.2	1.2	1.2
I	M4	M4	M4
X*	8	8	8

\*For DIN-rail mounting only.

## Input / Output Terminal (unit: mm)

Terminal Cross Sections	10~30A
Flex wire	1.3~2.5mm <sup>2</sup>
AWG tyep wire	AWG 16~13
Ring / Fork lug (W/d)*	Max. 11mm (9.5mm);
	Min. Ø4.3mm
Recom. Torque	1~1.2Nm

\*HAL recommends the use of insulated and UL-recognized ring lugs or fork lugs of the appropriate size.

# 3 PHASE FILTER

## 3 Wired

### Features

- Excellent conducted attenuation performance
- Noise attenuation range from 10kHz~30MHz
- Current rating 7A~400A
- Alternative performance grade
- Widely use in regenerative motor drivers

### Marketing Applications

- Regenerative motor drivers
- Elevators. Cranes
- UPS
- Automation equipment
- Traction control system

### Electrical Schematic

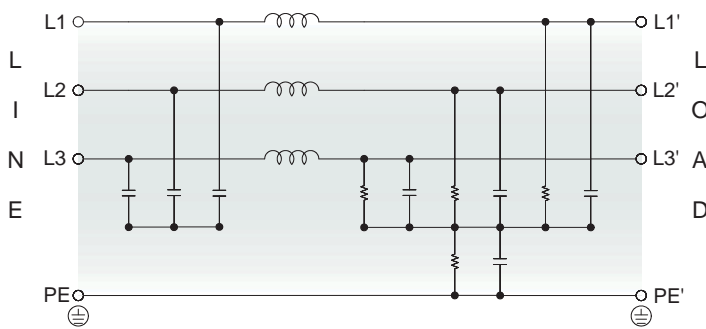

### Filter Selection Table •

Filter Project No.	Rated Current @50°C [A]	Typical Drive* Power Rating [kW]	Leakage Current** @400VAC/50Hz [mA]	Power Loss @25°C/50Hz [W]
07SCA00	7	4	48.9	3.8
08SCA00	8	4.5	48.9	4.0
10SCA00	10	5	48.9	4.5
16SCA00	16	7.5	48.9	6.1
20SCA00	20	10	48.9	7.8
25SCA00	25	13	48.9	10.5
30SCA00	30	15	48.9	11
36SCA00	36	22	48.9	11.8
40SCA00	40	23	48.9	14.8
42SCA00	42	25	48.9	15.7
50SCA00	50	30	48.9	18
55SCA00	55	35	48.9	25.9
60SCA00	60	40	48.9	28.5

\*Calculated at rated current, 600 VAC and  $\cos \phi = 0.8$ . The exact value depends upon the efficiency of the drive, the motor and the entire application.

\*\*Maximum leakage under normal operating conditions. Note: if two phases are interrupted, worst case leakage could reach 5.4 times higher levels.

### Filter Attenuation Insertion loss (dB) in 50 ohm system CISPR 17 (for reference only)

■ 7A~36A

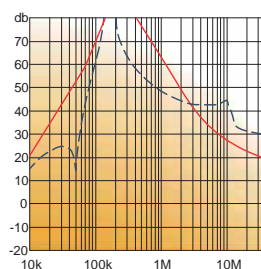

■ 40A~60A

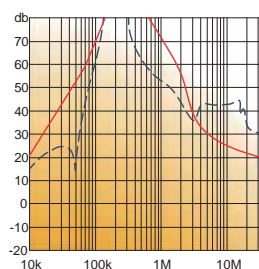

■ 80A~150A

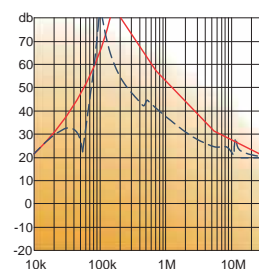

Common mode / Asymmetric (L-G) ————  
Differential mode / Symmetric (L-L) - - - - -

## Mechanical Drawing

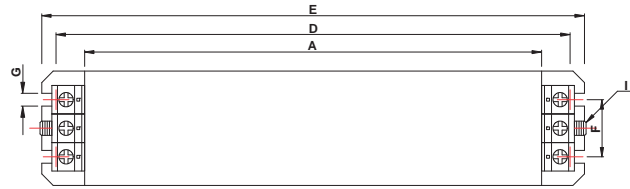
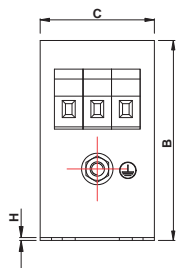

## Dimensions (unit: mm) Tolerances according to ISO 2768-m / EN 22768-m

Code	7~36A	40~60A	80A	110A	150A
A	335	329	379	379	438
B	60	80	90	90	110
C	150	185	220	220	240
D	305	300	350	350	400
E	320	314	364	364	413
F	35	55	65	65	80
G	6.5	6.5	6.5	6.5	6.5
H	1	1.2	1.2	1.2	1.2
I	M6	M6	M10	M10	M10

## Input / Output Terminal (unit: mm)

Terminal Cross Sections	7~36A	40~60A	80~150A
Solid wire	16mm <sup>2</sup>	35mm <sup>2</sup>	50mm <sup>2</sup>
Flex wire	10mm <sup>2</sup>	25mm <sup>2</sup>	50mm <sup>2</sup>
AWG type wire	AWG 6	AWG 2	AWG 1/0
Recom. torque	1.5~1.8Nm	4~4.5Nm	7~8Nm

# 3 PHASE FILTER

## 3 Wired

### Features

- Excellent conducted attenuation performance
- Noise attenuation range from 10kHz~30MHz
- Current rating 7A~400A
- Touch-safe connections with hinged safety covers
- Thin and lightweight, metal chassis construction

### Marketing Applications

- Variable-frequency drive
- Lifts. Hoists
- Rectifiers
- Servo motor
- High power office equipment

### Electrical Schematic

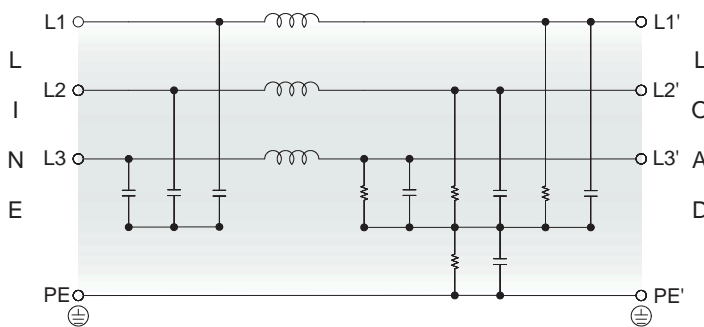

### Filter Selection Table •

Filter Project No.	Rated Current @50°C [A]	Typical Drive* Power Rating [kW]	Leakage Current** @480VAC/50Hz [mA]	Power Loss @25°C/50Hz [W]
07SCA20H	7	4	97.9	9
08SCA20H	8	4.5	97.9	11
10SCA20H	10	5	97.9	13
16SCA20H	16	7.5	97.9	15
20SCA20H	20	10	97.9	16
25SCA20H	25	15	97.9	17.1
30SCA20H	30	17	97.9	17.1
36SCA20H	36	22	97.9	17.2
40SCA20H	40	23	97.9	17.3
42SCA20H	42	25	97.9	17.4
50SCA20H	50	30	97.9	17.5
55SCA20H	55	35	97.9	25.9
60SCA20H	60	40	97.9	28.5

\*Calculated at rated current, 600 VAC and  $\cos \phi = 0.8$ . The exact value depends upon the efficiency of the drive, the motor and the entire application.

\*\*Maximum leakage under normal operating conditions. Note: if two phases are interrupted, worst case leakage could reach 5.4 times higher levels.

### Filter Attenuation Insertion loss (dB) in 50 ohm system CISPR 17 (for reference only)

■ 7A~25A

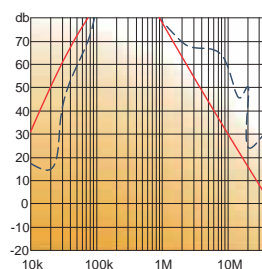

■ 30A~60A

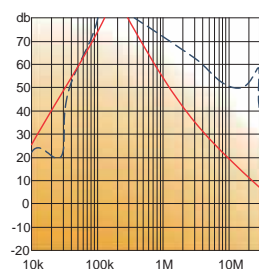

■ 80A~150A

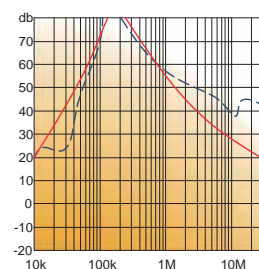

Common mode / Asymmetric (L-G) ————  
Differential mode / Symmetric (L-L) - - - - -

## Mechanical Drawing

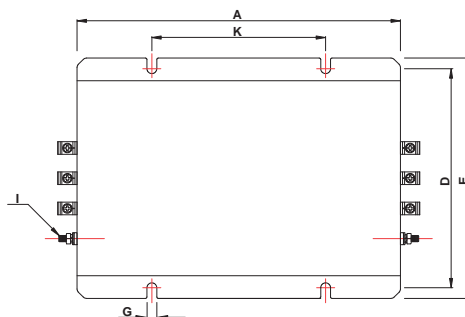
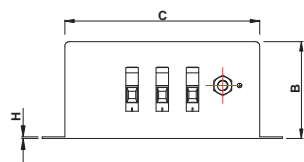

## Dimensions (unit: mm) Tolerances according to ISO 2768-m / EN 22768-m

Code	7-50A	55-80A	110A	150A
A	214	221	221	221
B	64	140	140	140
C	129	140	140	140
D	145	155	155	155
E	159	169	169	169
G	6.5	6.5	6.5	6.5
H	1	1	1	1
I	M6	M10	M10	M10
K	115	115	115	115

## Input / Output Terminal (unit: mm)

Terminal Cross Sections	7~25A	30~60A	80~150A
Solid wire	16mm <sup>2</sup>	35mm <sup>2</sup>	50mm <sup>2</sup>
Flex wire	10mm <sup>2</sup>	25mm <sup>2</sup>	50mm <sup>2</sup>
AWG type wire	AWG 6	AWG 2	AWG 1/0
Recom. torque	1.5~1.8Nm	4~4.5Nm	7~8Nm



# 3 PHASE FILTER

## 3 Wired

### Features

- Superior conducted attenuation performance
- Thin & lightweight metal housing book-style design
- Current rating 10A~400A
- Two-stage circuit is ideal for very noisy environments
- Ideal for distribution network

### Marketing Applications

- IT distribution network
- Inverters
- PV system
- Process control system (PCS)
- Wind turbine

### Electrical Schematic

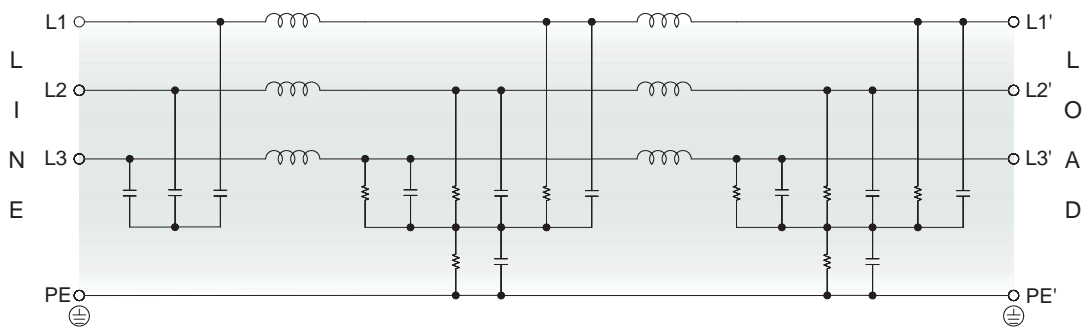

### Filter Selection Table •

Filter Project No.	Rated Current @50°C [A]	Typical Drive* Power Rating [kW]	Leakage Current** @440VAC/50Hz [mA]	Power Loss @25°C/50Hz [W]
10SB58	10	4	16.5	9
15SB58	15	7.5	18.3	15
20SB58	20	10	18.3	18
25SB58	25	12.5	18.3	21
30SB58	30	15	24.2	21
35SB58	35	17.5	24.2	30
55SB58	55	30	25.8	30
75SB58	75	37	25.8	24
100SB58	100	55	30	51
130SB58	130	75	13	50

\*Calculated at rated current, 600 VAC and  $\cos \phi = 0.8$ . The exact value depends upon the efficiency of the drive, the motor and the entire application.

\*\*Maximum leakage under normal operating conditions. Note: if two phases are interrupted, worst case leakage could reach 5.7 times higher levels.

### Filter Attenuation Insertion loss (dB) in 50 ohm system CISPR 17 (for reference only)

#### 10A~35A

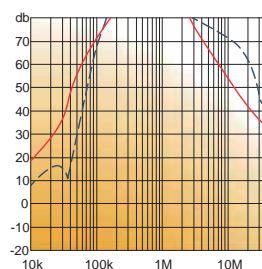

#### 42A~100A

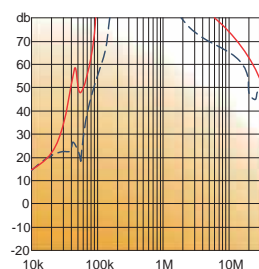

#### 130A

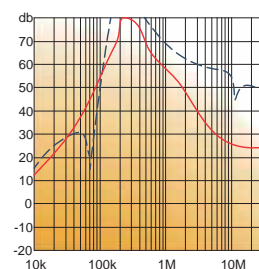

Common mode / Asymmetric (L-G) ————  
 Differential mode / Symmetric (L-L) - - - - -

## Mechanical Drawing

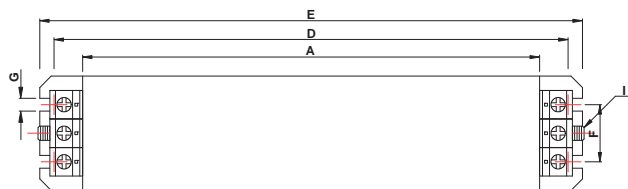
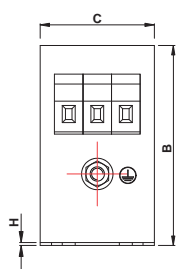

## Dimensions (unit: mm) Tolerances according to ISO 2768-m / EN 22768-m

Code	10A	15~20A	25~30A	35A	55A	75A	100A	130A
A	225	275	305	300	300	300	350	400
B	126	142	150	185	185	220	220	240
C	50	55	60	70	80	80	90	110
D	240	290	320	314	314	314	364	414
E	255	305	335	329	329	329	379	439
F	25	30	35	45	55	55	65	80
G	6.5	6.5	6.5	6.5	6.5	6.5	6.5	6.5
H	1	1	1	1	1	1	1	1
I	M5	M5	M5	M6	M6	M6	M10	M10

## Input / Output Terminal (unit: mm)

Terminal Cross Sections	10~20A	25~35A	55~75A	100~130A
Solid wire	10mm <sup>2</sup>	16mm <sup>2</sup>	35mm <sup>2</sup>	50mm <sup>2</sup>
Flex wire	6mm <sup>2</sup>	10mm <sup>2</sup>	25mm <sup>2</sup>	50mm <sup>2</sup>
AWG type wire	AWG 8	AWG 6	AWG 2	AWG 1/0
Recom. torque	1.5~1.8Nm	1.5~1.8Nm	4~4.5Nm	7~8Nm

# 3 PHASE FILTER

## 3 Wired

### Features

- General purpose
- Compact metal-shielded design
- Current rating 7A~400A
- Significant noise reduction in common & differential mode
- Widely used in industrial inverter

### Marketing Applications

- Industrial DC/AC inverters
- Computer numerical control (CNC)
- Transformers
- Travelator
- Converters

### Electrical Schematic

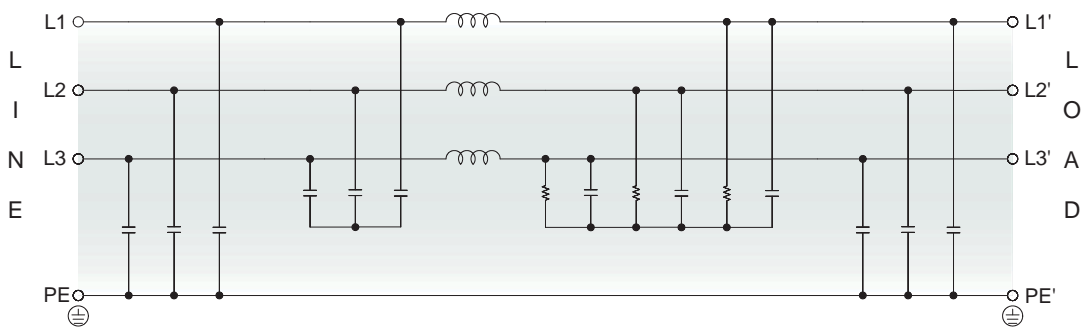

### Filter Selection Table •

Filter Project No.	Rated Current @50°C [A]	Typical Drive* Power Rating [kW]	Leakage Current** @400VAC/50Hz [mA]	Power Loss @25°C/50Hz [W]
07SC51H	7	3.5	2.3	6.5
08SC51H	8	4	2.3	7.0
10SC51H	10	5.5	2.3	7.5
16SC51H	16	7.5	2.3	8.0
20SC51H	20	10	2.3	8.5
25SC51H	25	15	32.7	9.0
30SC51H	30	16	32.7	9.0
36SC51H	36	18.5	32.7	9.0
40SC51H	40	21	32.7	9.5
42SC51H	42	25	32.7	10
50SC51H	50	30	32.7	11
55SC51H	55	34	32.7	13
60SC51H	60	36	32.7	14

\*Calculated at rated current, 600 VAC and  $\cos \phi = 0.8$ . The exact value depends upon the efficiency of the drive, the motor and the entire application.

\*\*Maximum leakage under normal operating conditions. Note: if two phases are interrupted, worst case leakage could reach 6 times higher levels.

### Filter Attenuation Insertion loss (dB) in 50 ohm system CISPR 17 (for reference only)

■ 7A~10A

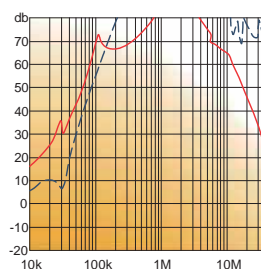

■ 16A

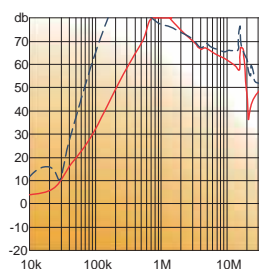

■ 30A~50A

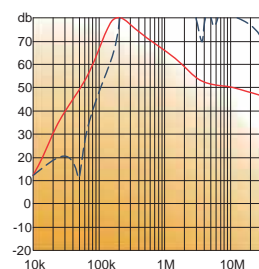

■ 80A~110A

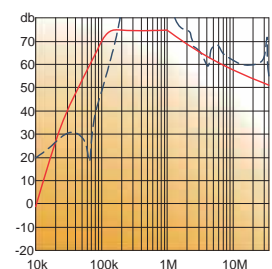

Common mode / Asymmetric (L-G) ————  
Differential mode / Symmetric (L-L) - - - - -

## Mechanical Drawing

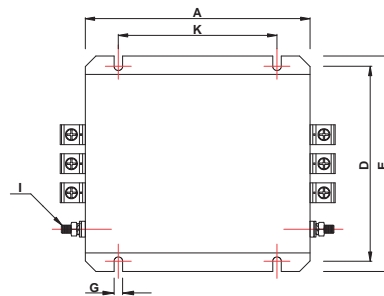
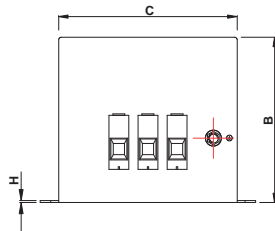

## Dimensions (unit: mm) Tolerances according to ISO 2768-m / EN 22768-m

Code	7~64A	80A	110A
A	200	400	400
B	65	90	90
C	120	350	350
D	136	130	130
E	150	170	170
G	6.5	15x6.5	15x6.5
H	1	1	1
I	M6	M10	M10
K	115	373	373

## Input / Output Terminal (unit: mm)

Terminal Cross Sections	7~20A	25~42A	50~64A	80~110A
Solid wire	6mm <sup>2</sup>	16mm <sup>2</sup>	35mm <sup>2</sup>	50mm <sup>2</sup>
Flex wire	4mm <sup>2</sup>	10mm <sup>2</sup>	25mm <sup>2</sup>	50mm <sup>2</sup>
AWG type wire	AWG 10	AWG 6	AWG 2	AWG 1/0
Recom. torque	0.6~0.8Nm	1.5~1.8Nm	4~4.5Nm	7~8Nm

# 3 PHASE FILTER

## 3 Wired

### Features

- Superior attenuation of common-mode noise
- Single stage circuit is ideal for general applications
- Current rating 7A~30A
- Touch-safe connections with hinged safety covers
- Light weight plastic housing design

### Marketing Applications

- Electric motor driven systems
- Frequency inverters
- Power management system
- Servo motor
- High power office equipment

### Electrical Schematic

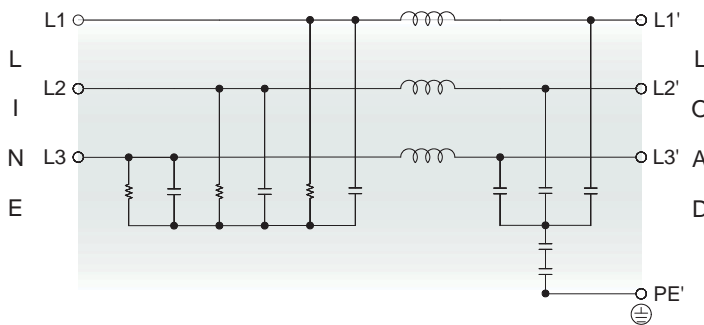

### Special Features

- CTAC series: best frequency bands from 150kHz~1MHz.
- CTAH series: best frequency bands from 10kHz~1MHz.

### Technical Data and Measuring Conditions

No.	CTAC series Filter PRJ No.	07CTAC	08CTAC	10CTAC	16CTAC	20CTAC	25CTAC	30CTAC	
	CTAH series Filter PRJ No.	07CTAH	08CTAH	10CTAH	16CTAH	20CTAH	25CTAH	30CTAH	
1	Rated voltage	AC Three phase 500V, 50/60Hz							
2	Rated current	7A	8A	10A	16A	20A	25A	30A	
3	Test voltage	2,000 VAC (Cutoff current: 100mA), 1 min. at room temperature and humidity							
4	Isolation resistance	500VDC 100MΩ min. at room temperature and humidity							
5	Leakage current	5mA @500V / 60Hz (max.)							
6	Cy cap. value	68nF							
7	Voltage drop	1.5V max.			1.0V max.				
8	Best frequency bands	CTAC series: 150kHz ~ 1MHz; CTAH series: 10kHz ~ 1MHz							
9	Safety approval temp.	-25° ~ +100°							
10	Operating temperature	-40° ~ +100°							
11	Operating humidity	20 ~ 95%RH (Non condensing)							
12	Storage temp. / humidity	-40° ~ +100°; 20 ~ 95%RH (Non condensing)							
13	Vibration	10 ~ 55Hz, 19.6m/s <sup>2</sup> (2G), 3 min. period, 1 hour each X,Y,Z axis							
14	Impact	196.1m/s <sup>2</sup> (20G), 11ms, once along X,Y,Z axis							
15	Safety approvals	UL1283, CSA C22.2 No.8 (C-UL), IEC/EN60939, ENEC							

## Mechanical Drawing

### • Chassis mounting

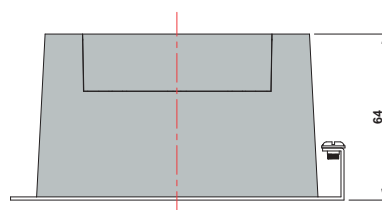
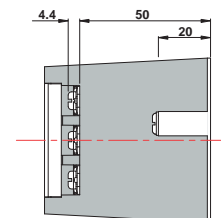
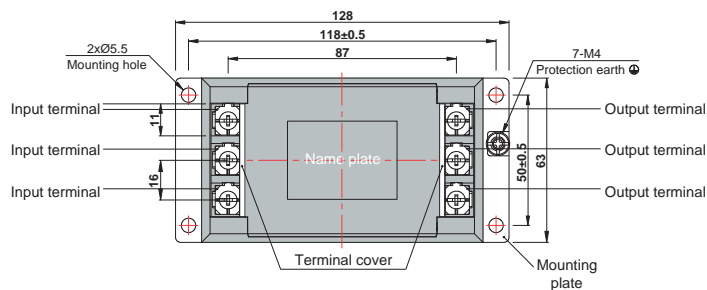

- ※ Tolerance: ±1
- ※ Case: PC
- ※ Mounting plate: Iron (surface finishing: nickel plating)  $t=1.2$
- ※ Terminal block screw tightening torque M4: 1.6N·m (16.9kgf·cm) max.

### • DIN-rail mounting

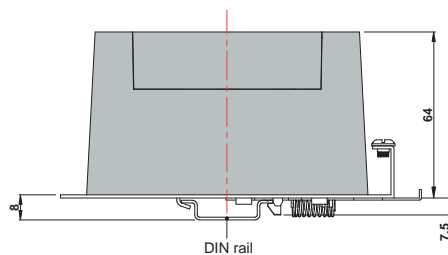
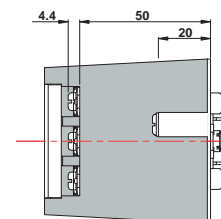
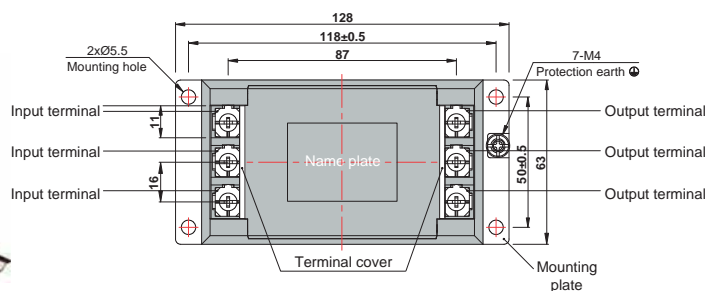

- ※ Tolerance: ±1
- ※ Case: PC
- ※ Mounting plate: Iron (surface finishing: nickel plating)  $t=1.2$
- ※ Terminal block screw tightening torque M4: 1.6N·m (16.9kgf·cm) max.

### Note when installing the EMI filter on a DIN rail:

When the EMI filter is grounded through the DIN rail, the proper noise attenuation may not be achieved. Be sure to connect the protection earth (PE) of the EMI filter body to the earth.

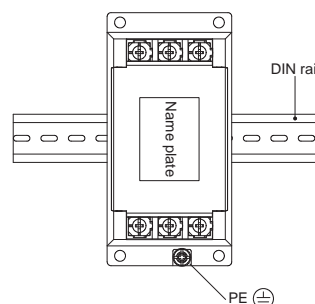

# 3 PHASE FILTER

## 4 Wired

### Features

- Very low leakage current values
- Excellent attenuation performance in grounding
- Current rating 7A~400A
- Extremely compact and lightweight design
- Alternative performance grade

### Marketing Applications

- Three-phase four-wire networks
- Automation
- Power distribution box
- Mainframe operation system
- UPS

### Electrical Schematic

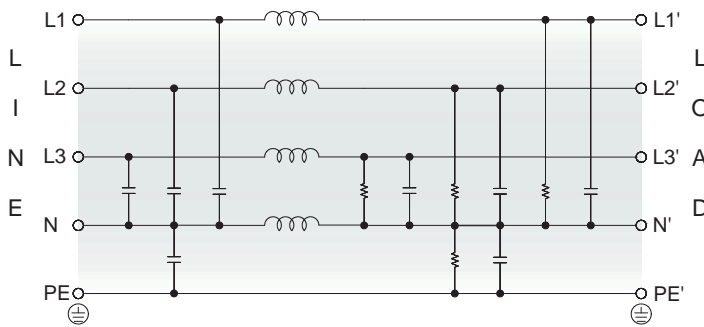

### Filter Selection Table •

Filter Project No.	Rated Current @50°C [A]	Typical Drive Power Rating [kW]	Leakage Current* @480VAC/50Hz [mA]	Power Loss @25°C/50Hz [W]
07SCB56H	7	3.7	<1	2.5
08SCB56H	8	4	<1	2.7
10SCB56H	10	5.5	<1	3.5
16SCB56H	16	7.5	<1	5
20SCB56H	20	8.5	<1	6.5
25SCB56H	25	10	<1	9.8
30SCB56H	30	12.5	<1	10.6
36SCB56H	36	15	<1	11.3
40SCB56H	40	17	<1	12.7
42SCB56H	42	18	<1	13.2
50SCB56H	50	19	<1	14.3
55SCB56H	55	20	<1	15.5
60SCB56H	60	21	<1	16.8

\*Maximum leakage under normal operating conditions, based on the assumption that all three phases and the neutral conductor are connected to the supply and the consumer. In this case, the current will mainly return through the neutral line, not as earth leakage.

### Filter Attenuation Insertion loss (dB) in 50 ohm system CISPR 17 (for reference only)

■ 7A~42A

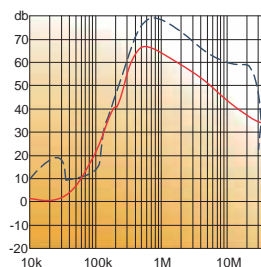

■ 50A~80A

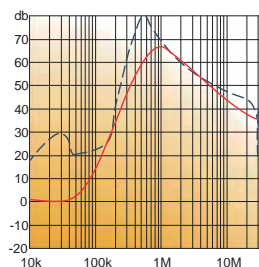

■ 120A

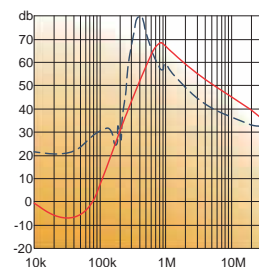

Common mode / Asymmetric (L-G) ————  
 Differential mode / Symmetric (L-L) - - - - -

## Mechanical Drawing

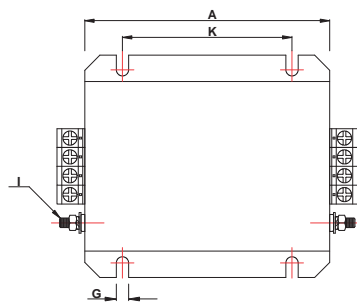
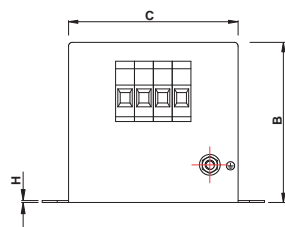

## Dimensions (unit: mm) Tolerances according to ISO 2768-m / EN 22768-m

Code	7~16A	20~42A	50~64A	80A	120A
A	110	130	140	170	210
B	70	85	115	125	125
C	82	90	115	135	140
D	94.5	102.5	127.5	147.5	153.5
E	110	118	143	163	170
G	6.5	6.5	6.5	6.5	6.5
H	1	1	1.2	1.2	1.2
I	M6	M6	M10	M10	M10
K	70	90	100	120	160

## Input / Output Terminal (unit: mm)

Terminal Cross Sections	7~16A	20~42A	50~64A	80~120A
Solid wire	6mm <sup>2</sup>	16mm <sup>2</sup>	35mm <sup>2</sup>	50mm <sup>2</sup>
Flex wire	4mm <sup>2</sup>	10mm <sup>2</sup>	25mm <sup>2</sup>	50mm <sup>2</sup>
AWG type wire	AWG 10	AWG 6	AWG 2	AWG 1/0
Recom. torque	0.6~0.8Nm	1.5~1.8Nm	4~4.5Nm	7~8Nm



# 3 PHASE FILTER

## 4 Wired

### Features

- General purpose
- Low leakage current values
- Current rating 7A~400A
- Touch-safe connections with hinged safety covers
- Widely used in industrial machinery

### Marketing Applications

- Three-phase four-wire networks
- Medical device (not body-coupled)
- Industrial electric appliances
- High power office equipment
- Power management system

### Electrical Schematic

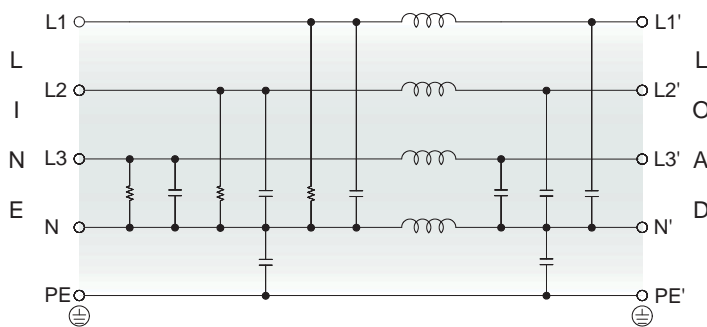

### Filter Selection Table •

Filter Project No.	Rated Current @50°C [A]	Typical Drive Power Rating [kW]	Leakage Current* @480VAC/50Hz [mA]	Power Loss @25°C/50Hz [W]
07SC56	7	3.7	0.43	3.5
08SC56	8	4	0.43	4
10SC56	10	5.5	0.43	5
16SC56	16	7.5	0.43	7
20SC56	20	8.5	0.43	9
25SC56	25	10	0.43	10.1
30SC56	30	12.5	0.43	10.6
36SC56	36	15	0.43	10.9
40SC56	40	17	0.43	12.7
42SC56	42	18	0.43	13.2
50SC56	50	19	0.43	15.8
55SC56	55	20	0.43	16.5
60SC56	60	21	0.43	18

\*Maximum leakage under normal operating conditions, based on the assumption that all three phases and the neutral conductor are connected to the supply and the consumer. In this case, the current will mainly return through the neutral line, not as earth leakage.

### Filter Attenuation Insertion loss (dB) in 50 ohm system CISPR 17 (for reference only)

#### ■ 7A~16A

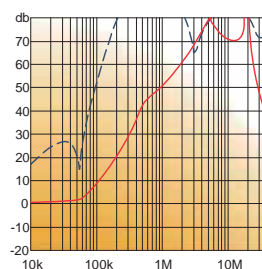

#### ■ 20A~60A

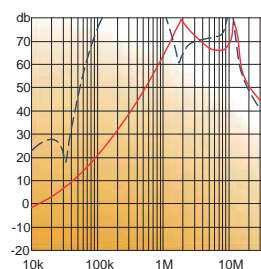

#### ■ 100A

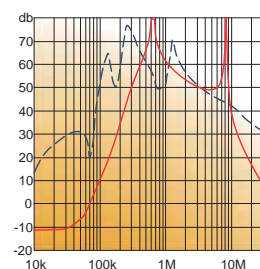

#### ■ 150A

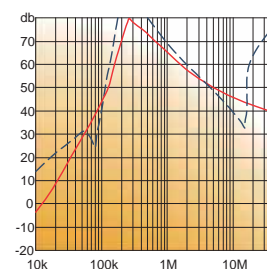

Common mode / Asymmetric (L-G) ————  
 Differential mode / Symmetric (L-L) - - - - -

## Mechanical Drawing

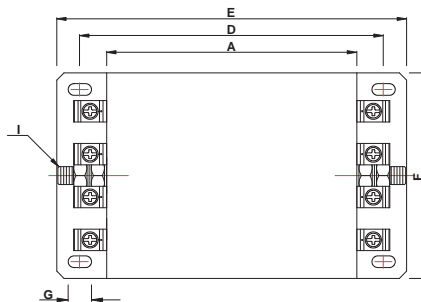
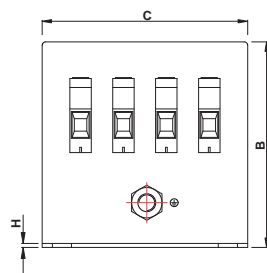

## Dimensions (unit: mm) Tolerances according to ISO 2768-m / EN 22768-m

Code	7~36A	40~60A	100A	150A
A	140	142.5	210	300
B	80	102	130	130
C	105	122	160	160
D	165.5	168	230	320
E	189.5	192	250	340
F	80	98	65	60
G	13x6.5	13x6.5	13x6.5	13x6.5
H	1	1	1	1
I	M6	M6	M10	M10

## Input / Output Terminal (unit: mm)

Terminal Cross Sections	7~16A	20~50A	60~100A	150A
Solid wire	6mm <sup>2</sup>	16mm <sup>2</sup>	35mm <sup>2</sup>	50mm <sup>2</sup>
Flex wire	4mm <sup>2</sup>	10mm <sup>2</sup>	25mm <sup>2</sup>	50mm <sup>2</sup>
AWG type wire	AWG 10	AWG 6	AWG 2	AWG 1/0
Recom. torque	0.6~0.8Nm	1.5~1.8Nm	4~4.5Nm	7~8Nm

# 3 PHASE FILTER

## 4 Wired

### Features

- The most cost-effective solution
- Extremely compact and space-saving
- Current rating 7A~20A
- Low leakage current values
- With fast-on quick connection

### Marketing Applications

- Three-phase four-wire networks
- Control units
- Pumps
- HVAC system
- Security systems

### Electrical Schematic

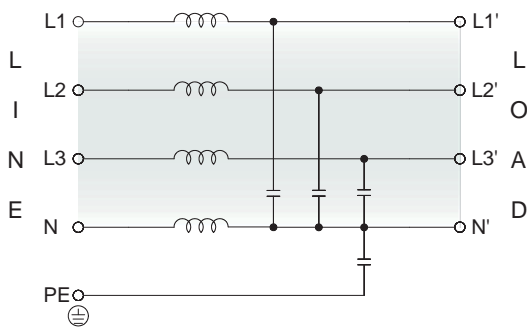

### Filter Selection Table

Filter Project No.	Rated Current @50°C [A]	Typical Drive Power Rating [kW]	Leakage Current* @480VAC/50Hz [mA]	Power Loss @25°C/50Hz [W]
07SC55	7	4	0.07	1.8
08SC55	8	7.5	0.07	3.6
10SC55	10	10	0.07	6
16SC55	16	13	0.29	10
20SC55	20	15	0.29	12

\*Maximum leakage under normal operating conditions, based on the assumption that all three phases and the neutral conductor are connected to the supply and the consumer. In this case, the current will mainly return through the neutral line, not as earth leakage.

### Filter Attenuation

Insertion loss (dB) in 50 ohm system CISPR 17 (for reference only)

■ 7A~8A

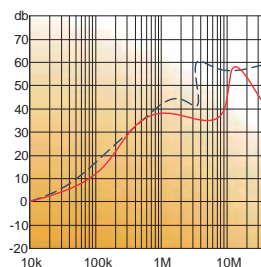

■ 10A~20A

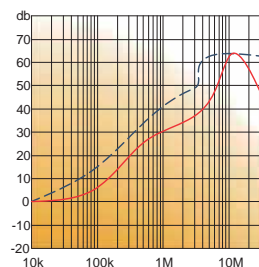

Common mode / Asymmetric (L-G) ————  
 Differential mode / Symmetric (L-L) - - - - -

# Mechanical Drawing

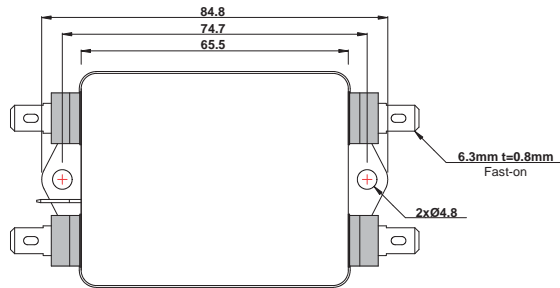
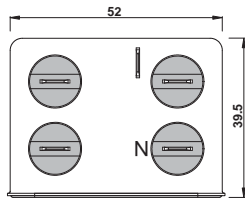

# INSTALLATION INSTRUCTIONS FOR FUSE

Following are step-by-step instructions for installing fuse(s).

## Step 1: Pull out the fuse holder

### 1-1

Use a slotted screwdriver (around 5mm) as shown in the belows insert into the point **B** and pry open with required force range in 0.13~0.2Nm.  
Note: Do not scratch the socket.

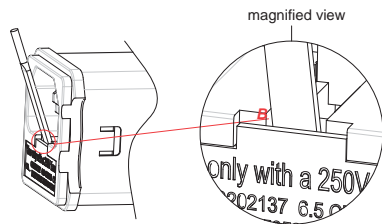

### 1-2

Pull-out force: 0.13~0.2Nm.

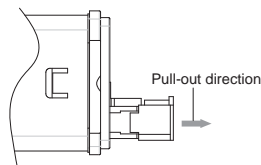

### 1-3

Completed.

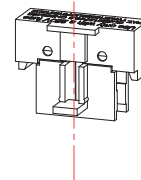

## Step 2: Install the fuse(s)

### 2-1

Load the fuse into the fuse holder at 45 degree inclination. Recom. contact force: 0.04~0.06Nm.

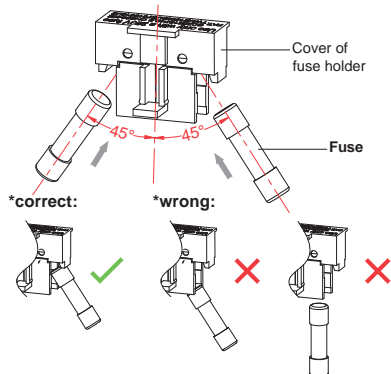

### 2-2

Place the fuse to vertical position.

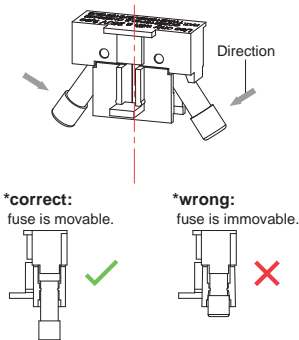

### 2-3

Completed.

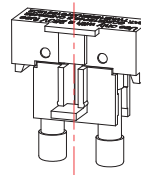

## Step 3: Push in the fuse holder

### 3-1

Push the fuse holder into the filter till hearing a "pop" sound, and that means it has been done successfully.

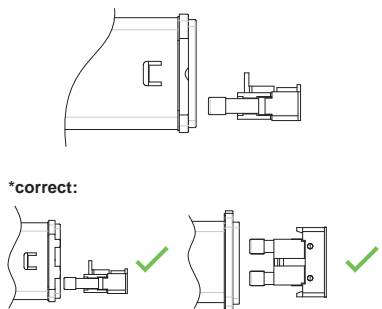

### 3-2

Push-in force: 0.13~0.2Nm.

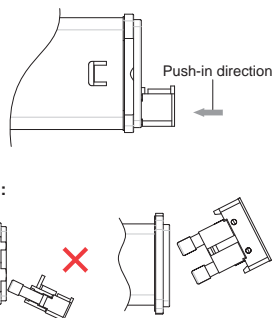

### 3-3

Completed.

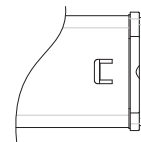

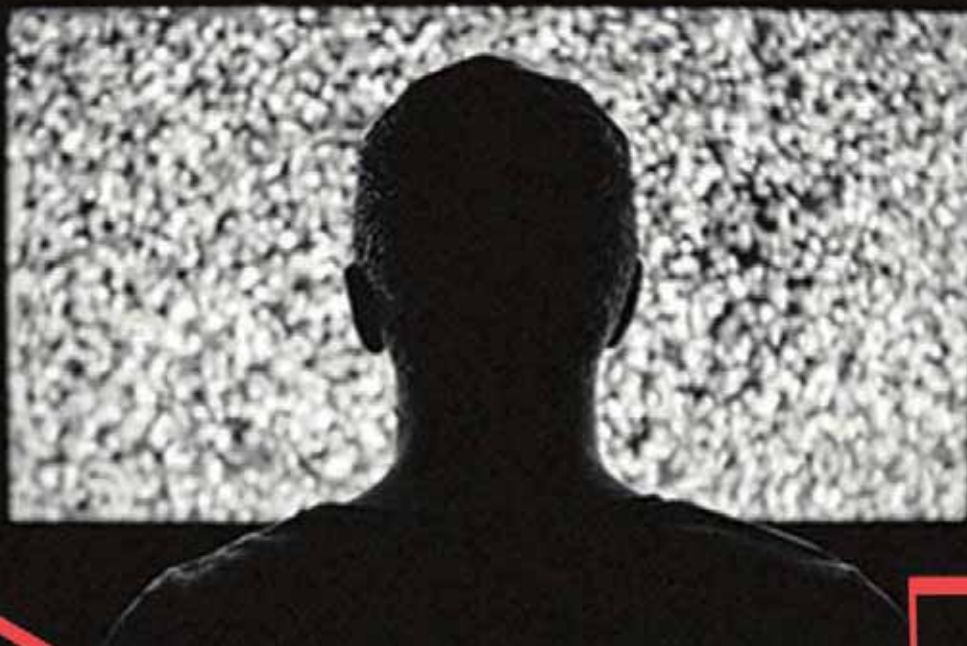

## EMC Compliance

Original Design Factory:

 *High & Low Corp.*

7F., No 118, Ln.235, Baoqiao Rd.,  
Xindian Dist., New Taipei City, Taiwan  
Tel: +886 2 8978 1800  
service@hal.com.tw  
www.hal.com.tw

UK & Ireland Distributor:

 **DAU**  
COMPONENTS

68-74 Barnham Road, Barnham,  
Bognor Regis, West sussex. PO22 0ES.  
Tel: +44 1243 553031  
Fax: +44 1243 553860  
technical@dau-components.co.uk