

GA02ADC001AB0  
With logo (Print Color=Silver)

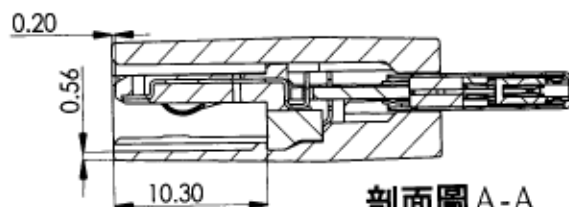
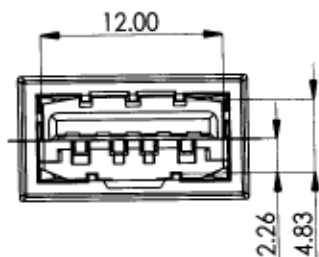

剖面圖 A-A

SPECIFICATION

MATERIAL

Insulator: Thermoplastic, rated UL94-HB

ELECTRICAL

Operation voltage: 5.0 V

Current rating: 0.5 Amps max.

Contact resistance: 80 mohms initial

Insulation resistance: 1000 Mohms min @ 500 VDC

Dielectric withstanding voltage: 500 VAC / minute

Temperature range: -0°C TO +60°C

Part no.

G A 02 A D C0 OX A B0  
1 2 3 4 5 6 7 8 9

1.SERIES NO.

G=Finished

2.A=Adapter

3.02=USB C Plug/USB 3.0 AF

4.A=TYPE A

5.GREEN OPTION:

D=RoHs2(matte)(Halogn-Free)

6.CUSTOMER NO:

C0=coxoc

7.Technology Code:

00=W/O logo

01=W/logo

8.A=TRAY

9.COLOR: B0=Black

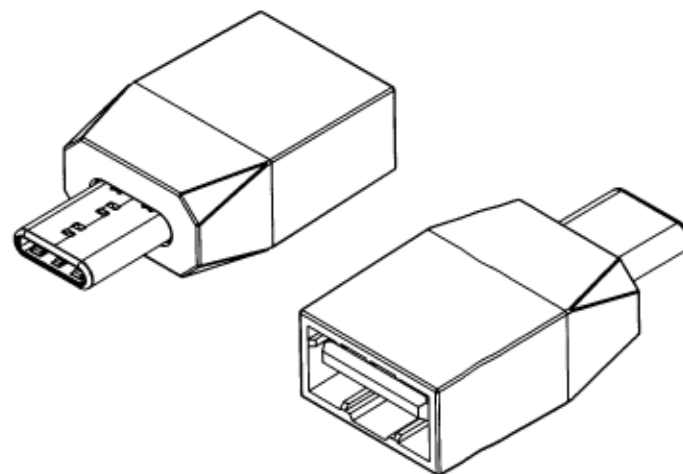

For SIP

(ST) For CmK/Cpk

UNLESS OTHERWISE SPECIFIED TOLERANCE

ANG.	± 2°
0.	± 0.50
.0	± 0.30
.00	± 0.20

SCALE: AS SHOWN

UNIT: mm

DRAWN: PEARL

10/05/2015

DRAWN NAME: USB C Plug to A(Legacy) Adapter (ID-A)

CHECKED: 林永福

10/05/2015

PRODUCT NO. C-GA02ADC00XAB0

APPROVED: 范政敏

10/05/2015

FILE NAME: C-GA02ADC000AB0(GB)

REV. A ECN-1510005(Sam) X1 Change A

DESCRIPTION

DATE



SIZE

A4

REV. A